



LICENTIATE THESIS IN
STRUCTURAL ENGINEERING AND BRIDGES
STOCKHOLM, SWEDEN 2016

Bridge Edge Beams

LCCA and Structural Analysis for the
Evaluation of New Concepts

JOSÉ JAVIER VEGANZONES MUÑOZ

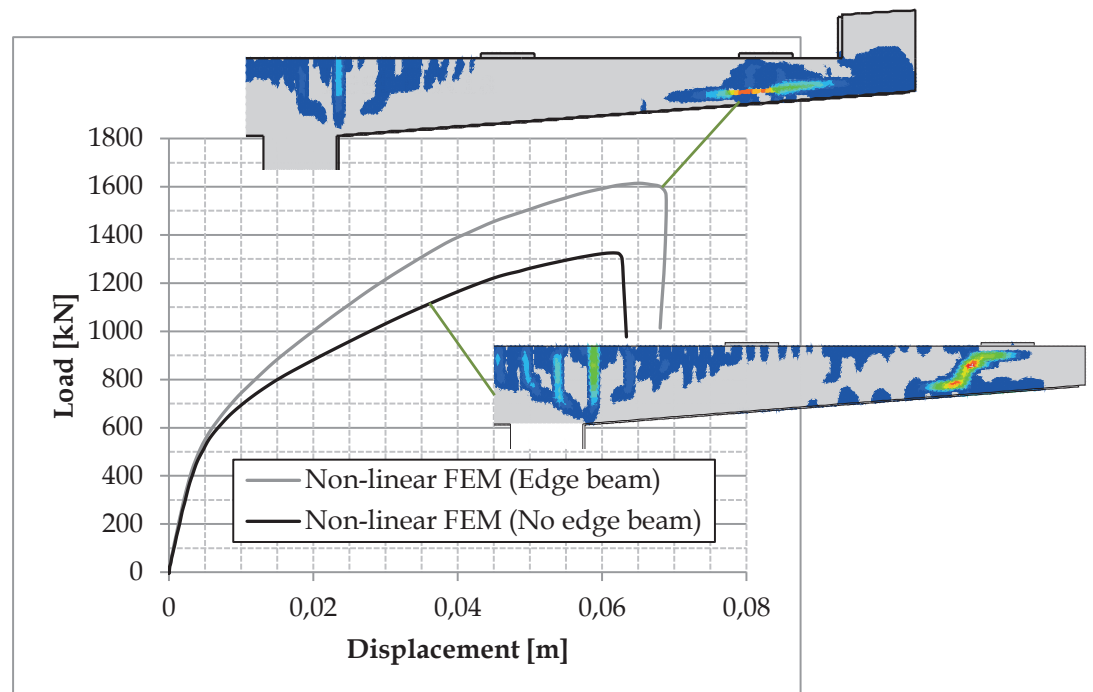



Bridge Edge Beams

**LCCA AND STRUCTURAL ANALYSIS FOR THE
EVALUATION OF NEW CONCEPTS**

JOSÉ JAVIER VEGANZONES MUÑOZ

Licentiate Thesis, 2016
KTH Royal Institute of Technology
School of Architecture and Built Environment
Department of Civil and Architectural Engineering
Division of Structural Engineering and Bridges
SE-100 44, Stockholm, Sweden

TRITA-BKN Bulletin 137, 2016
ISSN 1103-4270
ISRN KTH/BKN/B--137--SE

© José Javier Veganzones Muñoz, 2016

Akademisk avhandling som med tillstånd av KTH i Stockholm framlägges till offentlig granskning för avläggande av teknisk licentiatexamen fredagen den 12 februari kl. 13:00 i sal Stora konferensrummet (M108), KTH, Brinellvägen 23, Stockholm. Avhandlingen försvaras på engelska.

Abstract

Bridge edge beams in Sweden may involve up to 60% of the life-cycle measure costs incurred along the road bridge's life span. Moreover, user costs as means of traffic disturbances are caused. Consequently, the Swedish Transport Administration started a project to find better alternative edge beam design proposals for the society.

The goal of this thesis is to contribute to the development of bridge edge beam solutions that can result better for the society in terms of total cost and still fulfill the functional requirements, through the evaluation of new concepts. A life-cycle cost analysis was carried out to assess the proposed alternatives. The results served as a guidance to identify alternatives that could qualify for more detailed studies. One such proposal was a solution without edge beam. Since the edge beam is known to distribute concentrated loads, the removal of such member could lead to loss of robustness of concrete bridge deck slabs. Thus, a structural analysis to determine the influence of the edge beam was performed through non-linear finite-element modelling validated from experimental evidence available in the literature. An assessment of the existing calculation methods for the overhang slab is also presented.

The results show that the edge beam behaves as a load-carrying member which contributes to a wider distribution of shear forces. An increased load resisting capacity for reinforced concrete bridge deck overhang slabs was documented. The removal of the edge beam would imply loss of robustness in the bridge, which might have to be counteracted by an increase of the thickness of the deck slab.

Keywords

Edge beam, bridge edge beam system, life-cycle cost analysis, bridge deck, overhang slab, structural analysis, design methods, non-linear, finite element modeling.

Sammanfattning

Kantbalkar i Sverige kan orsaka upp till 60 % av drift- och underhållskostnader under bronns livslängd. Dessutom finns användarkostnader i termer av trafikantstörningar. Som en konsekvens startade Trafikverket ett projekt vars mål var att hitta kantbalkslösningar som kan anses samhällsoptimala.

Syftet med denna avhandling är att utveckla de kantbalksutförningar som kan bli bättre för samhället i form av kostnader och kan uppfylla de funktionella och strukturella kraven. En livscykelkostnadsanalys genomfördes för att undersöka de föreslagna lösningarna. Resultaten tolkades som en vägledning för att identifiera förslag som skulle kunna kvalificera sig för mer detaljerade studier. Ett förslag som visade sig vara intressant var en lösning utan kantbalk. Eftersom kantbalken kan fördela koncentrerade laster kan avlägsnandet av en sådan leda till förlust av robusthet av brobaneplattan. Således var inverkan av kantbalken på det strukturella beteendet det som undersöktes genom icke-linjära finit element modeller som validerades från laboratorieförsök i litteraturen. En bedömning av de nuvarande beräkningsmetoderna presenteras också.

Resultaten visar att kantbalken uppför sig som ett lastbärande element, som bidrar till en större spridning av tvärkrafter. En ökad lastkapacitet för betongarmerade brobaneplattor dokumenterades. Avlägsnandet av kantbalken skulle innebära förlust av robusthet i brobaneplattan. Detta skulle kunna lösas genom en ökning av plattans tjocklek.

Nyckelord

Kantbalkssystem, Livscykelkostnadsanalys, Brobaneplattor, Konsolplattor, Dimensionering, Finit Element Modellering.

Resumen

Las vigas de borde en puentes en Suecia pueden causar hasta el 60% de los costes de mantenimiento y reparación durante la vida útil de la estructura. Además, se generan al mismo tiempo altos costes de usuario debido al tráfico provocado por las obras. Por tanto, la Administración de Transportes de Suecia empezó un proyecto para encontrar mejores alternativas para las vigas de borde desde el punto de vista de la sociedad.

El objetivo de esta tesis es contribuir al desarrollo de soluciones de vigas de borde que puedan resultar mejor en términos de costes para la sociedad y que a la vez cumplan con los requisitos funcionales mediante la evaluación de nuevos conceptos presentados. Un análisis de costes de ciclo de vida se ha efectuado para investigar las propuestas e identificar aquellas que podrían ser consideradas para estudios futuros. Una alternativa interesante es un diseño sin viga de borde. Debido a que una de las funciones de la viga de borde es distribuir cargas concentradas, prescindir de este miembro podría causar una pérdida de capacidad estructural en el tablero del puente. Por consiguiente, la influencia de la viga de borde fue investigada mediante un análisis estructural por medio de modelos de elementos finitos no lineales previamente validados a través de experimentos de laboratorio disponibles en la bibliografía. Una evaluación de los métodos de cálculo basado en los códigos existentes fue realizada.

Los resultados muestran que la viga de borde se comporta como un elemento resistente que distribuye principalmente esfuerzos de cortante. También se ha observado un incremento en la capacidad de carga de la estructura. El hecho de prescindir de la viga de borde implicaría pérdida de capacidad resistente, que podría ser recuperada a través de incrementar el grosor de la losa de hormigón del tablero del puente.

Palabras clave

Sistema de vigas de borde, Costes de Ciclo de Vida, Dimensionamiento, Modelo de Elementos Finitos, Tableros de puentes.

Preface

This thesis was completed at the Division of Structural Engineering and Bridges in the Department of Civil and Architectural Engineering at the KTH Royal Institute of Technology. I would like to express my sincere gratitude to my supervisors Prof. Emeritus Dr. Håkan Sundquist, Dr. Lars Pettersson, Dr. Costin Pacoste and Dr. Raid Karoumi for having guided, helped and supported me during my work in the last two years. The funding from SBUF is greatly appreciated.

I wish to thank to all my institution colleagues for the valuable advice and discussions, and the good atmosphere provided. I also feel thankful to the waterpolo team of Stockholm Polisen for the exciting sport moments we have shared. I express my gratitude to Matthew Stephen “Alabama” for his help with a detailed English review of my first article.

My deepest appreciation goes to my parents José and María Pilar, my sisters María Estela, Irene and Talía, rest of family and friends who have encouraged me with a lot of affect from Spain and France, and my girlfriend Julie, who has supported me with patience and love during this first stage of the doctoral studies.

Finally and foremost I would like to thank God:

Have no fear of moving into the unknown. Simply step out fearlessly knowing that I am with you, therefore no harm can befall you; all is very, very well. Do this in complete faith and confidence. (St. John Paul II).

Stockholm, January 2016
José Javier Veganzones Muñoz

List of appended papers

This licentiate thesis is based upon the following two scientific articles:

Paper I

Veganzones Muñoz, José Javier; Sundquist, Håkan; Pettersson, Lars; and Karoumi, Raid (2015) “*Life-cycle cost analysis as a tool in the developing process for new bridge edge beam solution*”, Structure and Infrastructure Engineering, Volume 49, Pages 1737-1746. DOI: 10.1080/15732479.2015.1095770.

Paper II

Veganzones Muñoz, José Javier; Pacoste, Costin; Pettersson, Lars; and Karoumi, Raid. “*The influence of the edge beam on the structural behavior of bridge deck overhangs*” (Manuscript to be submitted for publication)

Both papers were planned, implemented and written by the first author. The finite element modelling was performed by the first author. The Co-authors have participated in the planning of the work and contributed to the papers with comments and revisions.

Nomenclature

Abbreviations

ACC	Accident costs
ADT	Average daily traffic
BEBS	Bridge edge beam system
EB	Edge beam
nEB	Without edge beam
INV	Investment
LCC	Life-cycle cost
LCCA	Life-cycle cost analysis
LCM	Life-cycle measure
LCP	Life-cycle plan
LCS	Life-cycle strategy
TDC	Traffic delay costs
VOC	Vehicle operation costs

Lower case Latin letters

a	Length of the bridge overhang
b_x	Width of the load in x -direction
b_y	Width of the load in y -direction
b_{eb}	Width of the edge beam
c	Distance of the load application point from the bridge overhang root
d	Effective depth at the considered cross-section
e	Eccentricity for the concrete damaged plasticity model
f	Coefficient for the Homberg-Rompers diagrams
f_c	Compressive strength of concrete measured on cylinders
f_{ct}	Tensile strength of concrete
f_u	Tensile strength of reinforcement
f_y	Yield strength of reinforcement
h_{eb}	Height of the edge beam
i_y	Moment of inertia per unit length of a slab strip

k_t	Factor accounting for a tapered height across the slab in the y -direction
l	Parameter accounting for the inner slab portions and the webs
m_x	Bending moment per unit length in the x -direction
m_y	Bending moment per unit length in the y -direction
n	Number of concentrated loads
p	Real interest rate
p_L	Nominal interest rate
p_i	Inflation
p_c	Benefit rate
s	Spring constant used for the beam on elastic foundation
s_{xe}	Parameter that accounts for the aggregate size
t	Parameter for the calculation of the bending moment (Sundquist)
t_1	Height of the slab at the root of the overhang
t_2	Height of the slab at the free edge of the overhang
t_p	Thickness of the surfacing
w	Vertical deflection
w_m	Distribution width for bending moment
w_s	Distribution width for shear
w_p	Control perimeter for a punching shear force
w_{mR}	Distribution width for bending moment for a resultant group of forces
w_{sR}	Distribution width for shear force a resultant group of forces
x_u	Height of the compression zone
y_{cs}	Distance from the center of the load to the root of the overhang
z	Effective shear depth

Upper case Latin letters

A'	Parameter used for the calculation of the bending moment
ADT	Average daily traffic
B_k	Parameter for the calculation of the bending moment (Sundquist)
$C_{Rd,c}$	Coefficient from experimental tests (shear strength of concrete)
D	Flexural rigidity of the concrete plate

D_k	Parameter for the calculation of the bending moment (Sundquist)
E_c	Elastic modulus of concrete
E_s	Elastic modulus of steel
F_{I1}	Coefficient for the calculation of the max. moment in the edge beam
F_{I2}	Coefficient for the calculation of the min. moment in the edge beam
I_s	Moment of inertia of the bridge slab overhang without the edge beam
I_{eb}	Moment of inertia of the edge beam
L	Length of a finite cantilever slab
LCC	Life-cycle cost
M	Bending moment
M_x	Longitudinal bending moment of the edge beam in the x -direction
P	A arbitrary placed concentrated load acting on the overhang
Q_{Rd}	Total concentrated load resisting capacity
V	Shear force
V_{Rd}	Shear resisting capacity of concrete per unit length of control perimeter
V_{ccd}	Top compressive concrete chord (shear resistance)
V_{td}	Bottom tensile reinforcement chord (shear resistance)
V_d	Design shear force per unit width

Lower case Greek letters

α	Direction of the principal resultant shear force
α_k	Parameter for the calculation of the bending moment (Sundquist)
ε	Strain
ε_s	Strain at the tensile reinforcement
λ	Parameter for the calculation of the bending moments
v_0	Principal resultant shear force per unit
v_d	Design shear force per unit width
v_{pav}	Shear force per unit width due to the pavement (overlay)
v_{perm}	Shear force per unit width due to the other permanent loads
v_Q	Shear force per unit length due to a (group of) concentrated load(s)
v_{SW}	Shear force per unit width due to the self-weight

v_x	Shear force per unit width acting in the x -direction
v_y	Shear force per unit length acting in the y -direction
v_{Rd}	Nominal shear resisting capacity of concrete
ξ	Factor accounting for the size effect in shear strength
ρ_l	Flexural reinforcement ratio
χ	Parameter for the calculation of the bending moments

Indexes

0	Principal (for shear)
cs	Critical section
d	Design
dist	Distributed
eff	Effective
lFE	Linear finite element
m	Bending moment
max	Maximum
min	Minimum
nlFE	Non-linear finite element
s	Shear
x	Coordinate x , x -axis direction
y	Coordinate y , y -axis direction
R	Resultant of a group of forces
Rd	Resisting capacity
ACI	According to the American Concrete Institute
CEN	According to the European Committee for Standardization
MC10	According to the Model Code 2010 (concrete shear resistance)
PPJ	According to Pacoste et. al. (distribution width)
BBK94	Boverkets Krav (Technical requirements for structures)
B11	Bro 11 (Swedish Transport Administration technical regulations)

Others

ACI	American Concrete Institute
CEN	European Committee for Standardization
Trafikverket	The Swedish Transport Administration
BaTMan	The Swedish Bridge and Tunnel Management

Contents

Abstract	iii
Sammanfattning	v
Resumen	vii
Preface	ix
List of appended papers	xi
Nomenclature	xiii
Contents	xvii
1. Introduction	1
1.1. Background	1
1.2. Aim, goals and objectives, and scope	4
1.3. Methodology	5
1.4. Research contribution	6
1.5. Structure of the report	7
2. The bridge edge beam system	9
2.1. Definition	9
2.2. Function	10
2.3. Classification	10
2.4. Durability	12
2.4.1. Life span	12
2.4.2. Deterioration initiated during the construction phase	13
2.4.3. Deterioration during the service life.....	13
2.4.4. Preventive maintenance.....	15
2.4.5. Corrective maintenance	17
2.5. Design solution proposals by the edge beam group	18
2.5.1. Concrete integrated edge beam.....	18
2.5.1. Without edge beam	19
2.5.2. Steel edge beam	20
2.5.3. Prefabricated concrete edge beam	21
2.5.4. Inspection path.....	23
2.6. International perspective	23
2.7. Aesthetics	24

3. Life-cycle Cost Analysis	27
3.1. Definition and components.....	27
3.2. The discount rate	28
3.3. Definition of a Life-cycle Strategy	29
3.4. LCCA of BEBS.....	32
3.4.1. Methodology.....	32
3.4.2. Bridge cases	33
3.4.3. Assumptions and limitations.....	35
3.4.4. The choice of the life-cycle strategy	35
3.4.5. Stainless steel alternatives.....	36
3.4.6. The influence of the discount rate	37
3.5. Summary.....	39
4. Structural analysis.....	41
4.1. The role of the edge beam	41
4.2. Swedish codes	43
4.2.1. Requirements in Bro 11 (TRVK).....	43
4.2.2. Recommendations in Bro 11	45
4.3. Design of bridge deck cantilever slabs	46
4.4. Flexural criterion.....	47
4.4.1. Simplified calculation methods	48
4.4.2. FE-calculations and distribution widths	54
4.5. Shear criterion.....	55
4.5.1. Simplified calculation methods	55
4.5.2. FE-calculations and distribution widths	58
4.5.3. Concrete shear resisting capacity	59
4.6. Experimental tests on RC cantilever slabs	62
4.7. Non-linear FE-analysis	65
4.7.1. Material definition	65
4.7.2. Analysis procedure.....	66
4.8. The influence of the edge beam	67
4.8.1. Development of design curves for moment.....	70
4.9. A solution without an edge beam.....	72
4.10. Summary.....	73
5. Conclusions	75
5.1. General conclusions.....	75

5.1.1. LCCA (<i>Paper I – Chapter 3</i>).....	75
5.1.2. Structural analysis (<i>Paper II – Chapter 4</i>)	76
5.2. Design and LCCA	77
5.3. Further research	78
References	81
Appended papers	89
Paper I	91
Paper II	111

1. Introduction

1.1. Background

In the last years the bridge edge beam system (BEBS) has become an increasing concern by bridge managers in Sweden. The rationale is the heavy deterioration observed in this bridge member. Consequently, life-cycle measures (LCM) need to be performed (**Figure 1**). In fact, the BEBS is exposed to harsh conditions such as weather, frost, splashed salt water and car collisions. The Swedish Transport Administration (in Swedish, "Trafikverket") documented that up to 60% of the total LCM costs of a bridge in Sweden are related to the BEBS. Besides, such preventive and, especially, corrective maintenance brings about undesired road user disturbances.



Figure 1: Examples of deteriorated BEBS in the need of LCMs to be carried out

As means of construction, the working conditions for BEBS are not favorable. Edge beams have usually an elevation from the overlay level that makes the formwork setting complicated. Besides, the concrete finishing is hindered by the anchoring bolts for the railing. These anchoring bolts also require precision in the execution to adequately match the position of the railing elements. This aspect is checked multiple times by surveyors before casting the concrete. Furthermore, construction joints are needed

for big sized edge beams, or for edge beams in long bridges. Such construction joints may aggravate their durability.

Trafikverket decided to create a group composed of bridge experts from the construction industry and the research division of the KTH Royal Institute of Technology. The purpose was to develop new design solutions that could become “more optimal for the society”. In total 24 proposals were presented and divided into 4 types. One of these corresponds to the concrete integrated edge beam, which is the standard design in Sweden. Alternative solution type for an enhanced durability is to prefabricate the edge beam *in situ* and then lift it onto the bridge deck’s formwork, before pouring the concrete.

The heavy deterioration of the BEBS eventually results in a replacement. Such LCM takes long time because of the new concrete cast and, hence, causes considerable user costs. As a consequence, a prefabricated steel solution was considered for faster replacements. Furthermore, in order to prevent unfavorable working conditions in the bridge construction, a solution with no actual edge beam was proposed. In such case, it has to be guaranteed that the functionality requirements – including structural – of the edge beam would still be met.

A Life-cycle Cost Analysis (LCCA) is often used in the bridge management field to assess and compare different structure and infrastructure proposals. It can also help to decide on an optimal life-cycle strategy (LCS) considering the remaining life span and the condition class (Veganzones Muñoz & Morán Quijano, 2013). This methodology has also been used for decision-making concerning specific bridge structural elements (Safi, 2013). Hence, a LCCA is contemplated as an adequate tool for the development of these new BEBS proposals, where all the involved parties (i.e. owner, user and society) are considered.

The condition class of the BEBS has to be adequate to ensure a good performance of the functionality requirements. **Figure 2** shows a series of accidents that took place in 2013 in the Tranarp Bridges. In total 84 vehicles – 40 of them trucks – were involved (Myndigheten för samhällsskydd och beredskap [Swedish Civil Contingencies Agency], 2013). The accidents were almost simultaneous in both bridges. One person passed away and 49 were injured (Ibid). The cause of the accident

was the slippery road from the frost combined with a foggy environment. This accident highlights the importance of the BEBS, which in this case had a remarkable behavior as no vehicle fell of the bridge, and so avoided an even more catastrophic accident.



Figure 2: Accident in the Tranarp Bridges (Leprince & Tomas, 2013; Gustavsson, 2013)

The railing is designed, tested and manufactured by specialized companies. However, it is the bridge engineer's duty to design the edge beam for the case of accidental loads from a vehicle crash. Furthermore, the edge beam needs also to be designed considering the self-weight, permanent loads (e.g. overlay) and service loads (e.g. vehicles). Crack control has to be performed, especially in those areas over intermediate supports in continuous beam bridges.

The edge beam contributes to the stiffness of the bridge overhang slab and helps to distribute concentrated loads. The Swedish codes, in contrast, do not allow taking into consideration the edge beam as load-bearing member. The rationale is that the bridge should be open during the execution of the edge beam replacement. Nevertheless, such structural contribution exists during the rest of the life span of the bridge. Hence, it is of interest to study the influence of the edge beam on the structural behavior of the bridge overhang slab. This effect can become paramount to investigate if a solution without edge beam were implemented in real bridge projects. A solution without edge beam might imply that the bridge overhang slab has to be thicker compared to today's solution with an edge beam. This alternative would also require a railing attached from the side, which is not used in Sweden by Trafikverket.

The design of the BEBS may also be affected by other factors that are non-structural. Since the BEBS is the most visible part of the bridge, aes-

thetical aspects are also present. Different techniques to produce more attractive designs exist.

Undoubtedly, a good performance of the BEBS from a multi-oriented perspective throughout the bridge's life span can be ensured by an effective connection between design and LCCA. An adequate design for the bridge case considered that can match a defined LCS would lead to lower costs and maximum benefit to the society.

1.2. Aim, goals and objectives, and scope

The aim of the thesis is to bridge the gap between design and LCCA in the field of BEBS. The goal is to contribute to the development of new bridge edge beam solutions that can become better for the society in terms of total cost and that can fulfill the functional and structural requirements through the evaluation of new concepts presented. In order to do that the objectives have been the following:

- Evaluation and comparison of the new type proposals of BEBS presented by the edge beam group with the aid of a comprehensive LCCA for a wide set of bridge cases typical in Sweden.
- Address the influence on the results of the values of relevant parameters used for the LCCA and discuss about the definition of an adequate LCS for the BEBS that can lead to lower total life-cycle cost (LCC).
- Proposition and assessment of BEBS solutions with enhanced durability as means of extending their life span by the use of stainless steel under a LCCA perspective.
- Analyze the influence of the edge beam on the structural behavior of bridge deck overhang slabs with respect to the load capacity and the failure mode through a validated non-linear finite element (FE) model.
- Evaluate the efficiency of existing design calculation methods in light of the presence or absence of an edge beam, and present research proposals for the development of design curves based on edge beam types to be used by bridge engineers.
- Study from a structural perspective the possibility of the development of a solution without edge beam and its implications on the

concrete bridge deck slab, and reflect about its construction and durability aspects.

This thesis focuses on road bridges with overhangs, typically slab-on-girder bridges or cross-sectional box beam bridges.

1.3. Methodology

In order to achieve the aforementioned objectives, the methodology followed consisted of three main steps, namely: literature study, LCCA and structural analysis.

The literature study focused on information about existing BEBS types in Sweden and internationally, issues concerning durability of the BEBS and design aspects to take into consideration. A collection of reports is presented in Veganzones Muñoz (2014). The project was started in 2013 and was integrated into the edge beam group, which enabled to attend the meetings, participate in the discussions held and follow the procedure for the presentation of design proposals.

A LCCA was decided to be used as a tool to assess and compare the proposals presented by the edge beam group in terms of cost. The results served to identify which of them could qualify for further detailed studies and be implemented on a real bridge project. The LCCA was carried out following a classical scheme where owner, user and society costs are contemplated. An Excel-based application was developed for that purpose.

In order to study in detail the structural behavior of the bridge deck overhang slab with and without edge beams a non-linear 3D FE-model was created. For the validation of the FE-model, experimental tests of reinforced concrete (RC) deck slabs without an edge beam were resembled. Then, an edge beam was added to study its influence on the structural behavior. The failure mechanisms for different designs were observed. The results obtained with classical design methods were used to compare with the outcome from the experimental tests and the non-linear FE-model. The implications of the removal of the edge beam were discussed.

Master Theses' projects from KTH Royal Institute of Technology supported this study. Several meetings and seminars were organized with the

supervisors from the bridge research division at KTH Royal Institute of Technology, with the participation of Trafikverket's bridge managers and the bridge industry.

1.4. Research contribution

This thesis is meant to represent a stepping stone for the research in the field of BEBS. LCCA and structural aspects are investigated for the evaluation of new concepts in this field.

- Contribution to the proposal and development of new BEBS design solutions that can result optimal for the society in terms of cost.
- Evaluation and comparison from a LCC perspective of the presented design group alternatives. Investigation of the proposals that could qualify for further detailed studies and be implemented in real bridge projects.
- Study of the possibility of the use of stainless steel as means of extending the life span of the BEBS. Proposal of different alternatives. Performance of an economical evaluation, addressing the influence of the discount rate.
- Development of a non-linear FE-model that can resemble the shear failure of RC deck overhang slabs with and without an edge beam. Prediction of the load capacity.
- Demonstration of the load-carrying behavior of the edge beam. Evaluation of its magnitude as means of increased load capacity of the RC overhang slab. Investigation of an efficient distribution of the shear load capacity.
- Assessment of the existing design methods used for the bridge deck slab's overhangs and comparison with a former code used in Sweden. Investigation of their efficiency considering the load capacity from experimental tests in the literature, and the influence of an edge beam. Reflection on the robustness of Swedish bridges.

- Contribution to a detailed development of a proposal without an edge beam, addressing possible implications on the design of the RC overhang slab.

1.5. Structure of the report

This thesis begins with a first introductory chapter, in which the background, the aim and scope, the methodology of investigation and the research contribution are presented.

Chapter 2 consists of defining and characterizing the BEBS. A classification is presented according to different sources. Durability as means of life span, and preventive and corrective maintenance is illustrated. The group proposals of the edge beam project are shown. Aesthetical aspects are described.

Chapter 3 elaborates on the use of a LCCA in order to evaluate and compare the BEBS design alternatives, including the standard solution in Sweden. The influence of the discount rate is presented. The definition of an adequate LCS is addressed. The use of stainless steel as reinforcement in a concrete integrated edge beam is studied from a LCC perspective.

Chapter 4 deals with the design of RC overhang slabs considering the presence and absence of an edge beam. An overview of the Swedish codes as means of requirements and recommendations is presented. A literature background regarding the classical design methods for bridge cantilever slabs with respect to bending moments and shear forces is presented. Calculations using a linear-elastic FE-model and the use of distribution widths are covered. Experimental evidence to understand the behavior of overhang slabs is shown. Background to the development of a 3D non-linear FE-model is presented. The influence of an edge beam in linear-elastic FE-analyses is illustrated. Finally, an overview of a solution without an edge beam is shown.

Chapter 5 presents the main conclusions of the work in this thesis. A reflection on design and LCCA is provided. Future work proposals to be performed for the continuation of this research project are described.

The two papers of which this work is based on are presented at the end of this report. **Paper I** evaluates and compares proposal types presented

by the edge beam group with the aid of a comprehensive LCCA. The influence of parameters used is addressed. The positive influences on the LCC of a stainless steel reinforced solution and of the enhanced construction technique are estimated. **Paper II** investigates the influence of the edge beam on the structural behavior of RC bridge deck overhangs. A validated non-linear FE-model is presented to predict the behavior of the overhang slab subjected to concentrated loads. The efficiency of simplified design methods is evaluated. Possible implications from a structural point of view of the removal of the edge beam are presented.

2. The bridge edge beam system

2.1. Definition

The *edge beam* is a bridge structural member whose main functions are to provide an adequate attachment to the railing, support the overlay (pavement), contribute to the drainage system, distribute concentrated loads and be aesthetically pleasant.

The *bridge edge beam system* – BEBS – (**Figure 3**) is defined as a group of structural and non-structural bridge members composed of:

- a) The edge beam
- b) The railing
- c) The drainage system
- d) Secondary elements: lightning poles, sound barriers, protection from splashed water, protection nets, curb system, etc.

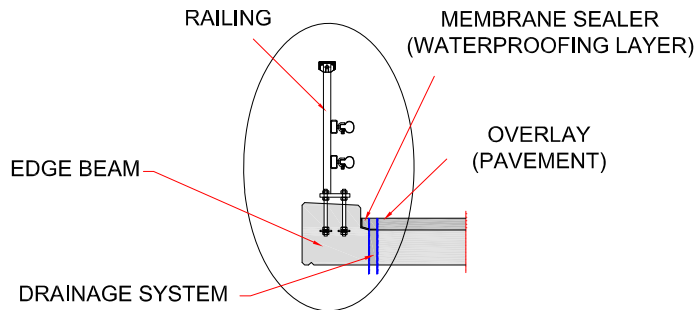

Figure 3: A typical bridge edge beam system (BEBS)

In some cases the bridge deck membrane sealer and the overlay located close to the edge beam are also included as part of the BEBS. The ra-

tionale is that the LCMs related to these parts are carried out simultaneously in order to reduce user disturbances (user costs).

2.2. Function

The following requirements should be fulfilled:

- a) The edge beam:
 - Provide an adequate railing attachment
 - Distribute concentrated loads
 - Contribute to the drainage
 - Provide support for the overlay (pavement)
 - Be aesthetically pleasant
- b) The railing:
 - Keep vehicles from not falling of the bridge.
- c) Drainage system:
 - Dewater the bridge deck slab.
 - Collect the contaminated water.

2.3. Classification

Trafikverket's bridge and tunnel management system (BaTMan) distinguishes the edge beam types according to the level of the overlay, as displayed in **Figure 4** (Trafikverket, 2013):

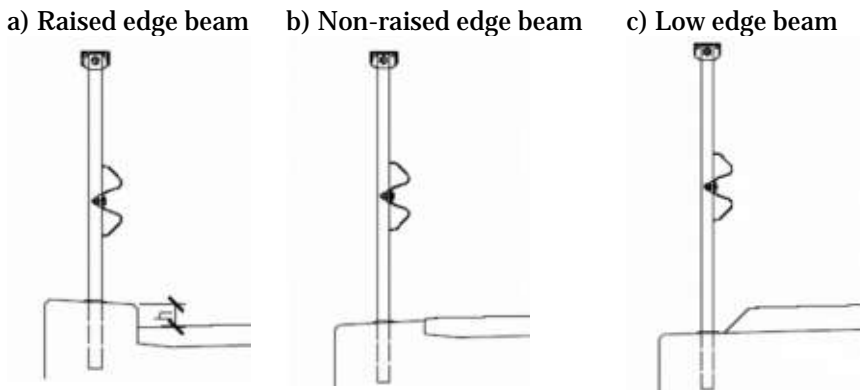

Figure 4: Edge beam types according to BaTMan (Trafikverket, 2013)

Fasheyi (2013) presented a more comprehensive classification, referring to the BEBS and its different components:

a) According to the design (**Figure 5**):

- Integrated edge beam
- Non-integrated edge beam (in Swedish, “brokappa”)

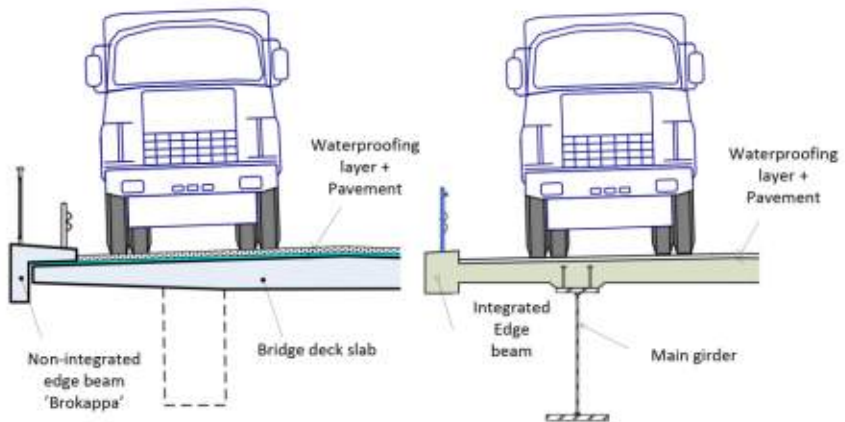

Figure 5: BEBS types according to the design, adapted from Sundquist (2011)

b) According to the drainage system (same as BaTMan, Figure 4):

- Raised edge beam
- Non-raised edge beam
- Low edge beam

c) According to the type of railing (**Figure 6**)

- Steel railing
 - i. Post attached by bolts and nuts
 - ii. Post cast into a recess
- Concrete barrier
 - i. Integrated
 - ii. Non-integrated
- Mixed steel-concrete



Figure 6: BEBS with different railing types: a) steel, b) concrete and c) mixed

2.4. Durability

2.4.1. Life span

The life span of edge beams was discussed in Mattson, Sundquist, & Silfwerbrand (2007). A survival analysis concluded that the real median life span is 58 years for European graded roads, and 75 years for the rest of roads in a sample size of 1850 bridges from the Mälardalen region (**Figure 7**). This result could be justified because of the difference in the high average daily traffic that causes more deterioration. However, the fact that European roads are prioritized for the maintenance compared to other roads should be considered. Silfwerbrand (2008) stated that brand new concrete edge beams should perform adequately at least more than 45 years.

In fact, any estimation of the life span of the BEBS is uncertain because a group of bridge members is involved – not only the edge beam –. Moreover, several factors are influencing the performance. Normally, the condition class of a single member will determine the life span of the BEBS. In reality, the life span of the BEBS can be highly related to the bridge deck membrane sealer (waterproofing layer) and the overlay (pavement). Since the LCM intervals for such members can be considered known, a bridge manager can decide to carry out LCMs related to the BEBS simultaneously. This issue is further discussed in **Chapter 3**. The condition class of a member can be influenced by certain factors. Examples of such are the average daily traffic (ADT), the kind of edge beam, the type of materials used, the climate zone, the road type and category, or the type and owner of the bridge.

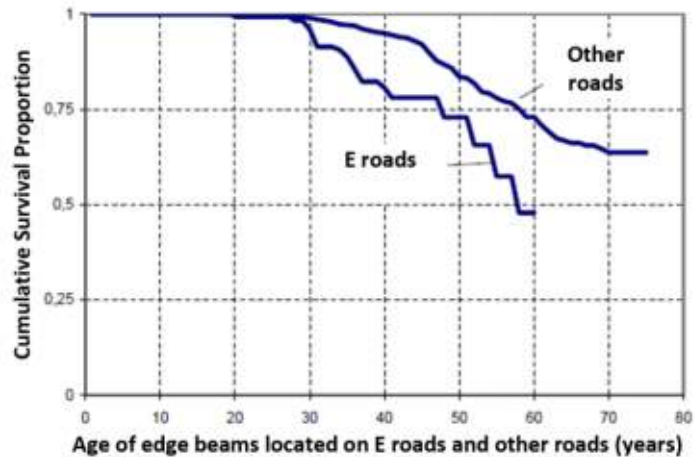

Figure 7: Survival curve for edge beams located in European roads and other roads in the Mälardalen region (Mattson, Sundquist, & Silfwerbrand, 2007)

2.4.2. Deterioration initiated during the construction phase

The following mechanisms bring about the deterioration of the BEBS during the concrete cast during the construction phase in a new bridge or the edge beam replacement:

- a) Plastic shrinkage cracks.
- b) Thermal contraction cracks. The formation of concrete cracks during the cooling of concrete when replacing the edge beams was studied in Samuelsson (2005).
- c) Bad execution of works.

2.4.3. Deterioration during the service life

Racutanu (2001) revealed that one-third of the bridge damage noted in a large sample of Swedish bridges is related to the BEBS (**Figure 8**).

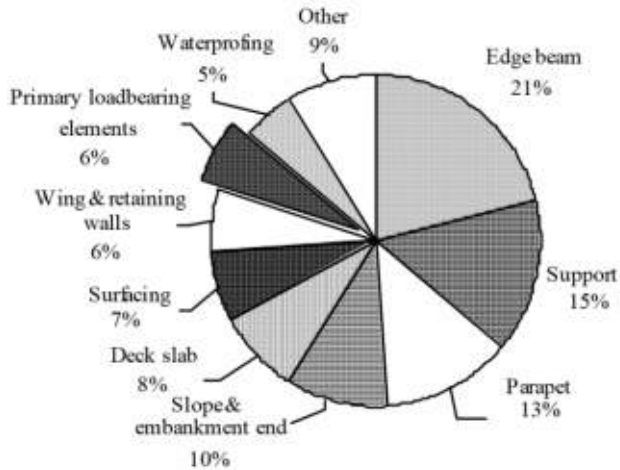

Figure 8: Percentage distribution of damage remarks from a sample made of 353 bridges in different parts of Sweden (Racutanu, 2001)

The following mechanisms bring about the deterioration of the bridge edge beam system during the service life:

- a) Steel corrosion (**Figure 9a**), caused by
 - Chloride attack
 - Sulfate attack
 - Carbonation in the concrete
- b) Concrete cracking and, subsequently, spalling (**Figure 9a**), caused by
 - Loading
 - Freeze-thaw
 - Corrosion in the steel
 - Vegetation growth
- c) Failure (**Figure 9b**), caused by
 - Vehicle collision
 - Collapse of the bridge

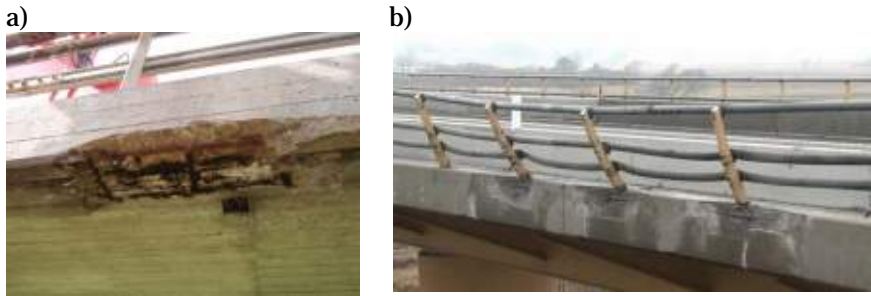

Figure 9: a) Steel corrosion and subsequent concrete spalling, and b) Failure of the bridge edge beam system because of a vehicle collision

Critical locations where this deterioration occurs are listed below:

- a) Areas close to the dewatering pipes in the bridge deck (**Figure 10a**).
- b) Expansion joints (**Figure 10b**)
- c) The connection of the railing post and the edge beam, for old bridges where the attachment of the railing is carried out by placing the post into a recess and casting concrete subsequently (**Figure 10c**). Nowadays cast in bolt attachment is a requirement.



Figure 10: Critical locations of the BEBS: a) Drainage, b) Expansion joints, c) Railing post

2.4.4. Preventive maintenance

LCMs corresponding to preventive maintenance are listed below:

- Major and minor inspections
- Operation and maintenance
 - Impregnation, which consists of applying an impermeable layer on the concrete in order to protect the reinforcement from chloride attack and subsequent corrosion. The use of impregnation is discussed in

Silfwerbrand (2008) where it was concluded that it is more cost-effective to apply it into old bridges rather than modern ones.

- Railing repainting, which used to be carried out some years ago for corroded railings. Recently Trafikverket has considered that this LCM is not cost-efficient anymore.

As preventive maintenance it can be also understood the use of materials or techniques that can extend the life span of the BEBS. In this regard, the durability of steel is paramount since corrosion is the main driving factor causing deterioration in RC. Recently in Sweden two ways to control corrosion have been applied:

- **Cathodic protection**, which consists of introducing an anode so that the reinforcement becomes the cathode in the electrochemical cell. This technique has been used in the Öland's bridge (**Figure 11**). A LCCA showed that this alternative was the most adequate in comparison to other solutions, included stainless steel (Maglica, 2012). In order to use cathodic protection, the reinforcement must have an adequate resistance capacity, i.e. the steel should not be heavily corroded. The approximated cost is 6000-7000 SEK/m-edge beam. It also requires annual inspection. The additional life span estimated is of 30 years.



Figure 11: a) Installation of cathodic net and b) concrete cast in the edge beams of the bridge in Öland (Maglica, 2012).

- **Stainless steel**, which reduces the corrosion speed. A life span of 120 years can be reached according to the Eurocode. A stainless steel edge beam can be considered maintenance free. Not only does this have a positive effect on LCM costs, but also on user

costs. Other advantages of stainless steel are that the concrete cover can be reduced to 30 mm and that it can be recycled up to 90%. Trafikverket has recently replaced an edge beam using stainless steel in a bridge with high *ADT* in order to prevent future maintenance (**Figure 12**). A disadvantage is the material price, which is estimated to be 4-6 times more expensive than normal carbon steel. However, if considered all construction costs (material, machinery and labor), this difference may not become significant. A LCCA for a standard concrete integrated edge beam is presented in **Chapter 3**.

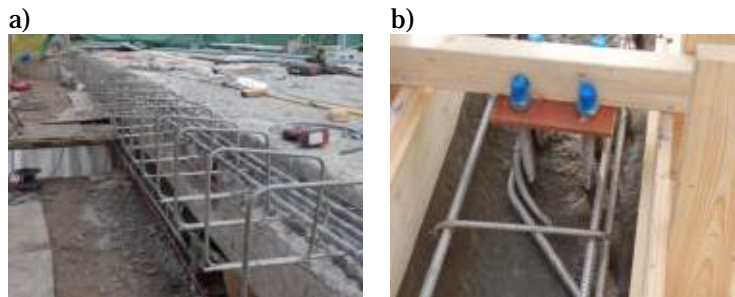

Figure 12: Edge beam replacement with stainless steel reinforcement

2.4.5. Corrective maintenance

LCMs corresponding to corrective maintenance are listed below:

- Repair, replacement & rehabilitation:
 - Concrete repair, which normally consists on sealing the existing cracks. The surface of the damaged area is hammered and cleaned. Binding material and a new layer of concrete is applied. Different damage categories exist: 0-30, 30-70, 70-100, and >100 mm.
 - Edge beam replacement, where the heavily damaged edge beam is cut using a water-jet technique. The formwork and the reinforcement are set, and a new edge beam is cast *in situ*.
 - Railing replacement, which can be caused because of a vehicle collision, or the edge beam replacement.

- Drainage system replacement, because of a bad performance of the former system due to deterioration or vegetation growth, among others.
- Recycling & disposal, after an edge beam replacement, or at the end of the bridge's life span.

2.5. Design solution proposals by the edge beam group

The edge beam group was created in order to present alternative proposals for the design of the BEBS. The project was conducted at the KTH Royal Institute of Technology in cooperation with Trafikverket and the construction industry. The project started June 2012 and finished November 2014. The group presented 24 alternative design solutions proposals in total, which were divided in 4 groups (Pettersson & Sundquist, 2014):

1. Concrete integrated edge beam ("Platsgjuten kantbalk")
2. Without edge beam ("Utan egentlig kantbalk")
3. Steel edge beam ("Stålkantbalk")
4. Prefabricated concrete edge beam ("Prefabricerad kantbalk")

A fifth group including an inspection path was also proposed. In this report only a design proposal of each group will be presented. The rest of the design solutions are presented in Pettersson & Sundquist (2014).

2.5.1. Concrete integrated edge beam

The concrete integrated edge beam is the standard solution in Sweden. The edge beam is cast *in situ* with the rest of the concrete deck slab. The railing is attached afterwards. The minimum recommended dimensions by Trafikverket are 400x400 mm² (Trafikverket, 2011b). In reality, larger dimensions may be needed because of the space needed for the reinforcement, typically 450x450 mm². Other recommendations and requirements are presented and discussed in **Section 4.2**. A typical design is shown in **Figure 13**.

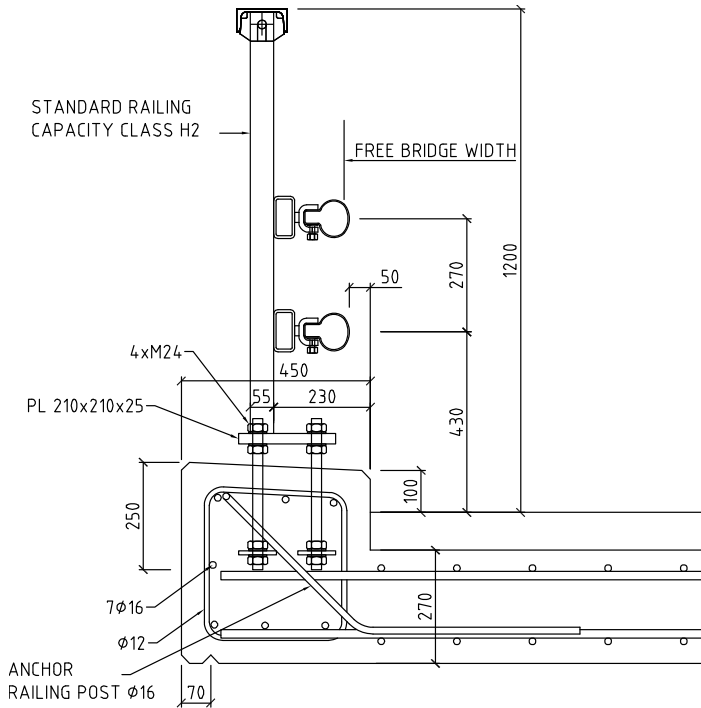

Figure 13: Group I - Concrete Integrated Edge Beam

2.5.1. Without edge beam

In this design alternative there is no actual edge beam. A continuous L-steel profile is anchored to the deck in order to support the overlay and contribute to the drainage system. The railing may be attached from the side or from the top, in the latter case with the help of a horizontal plate. This solution has not been used in Sweden yet. A design proposal is presented in **Figure 14**.

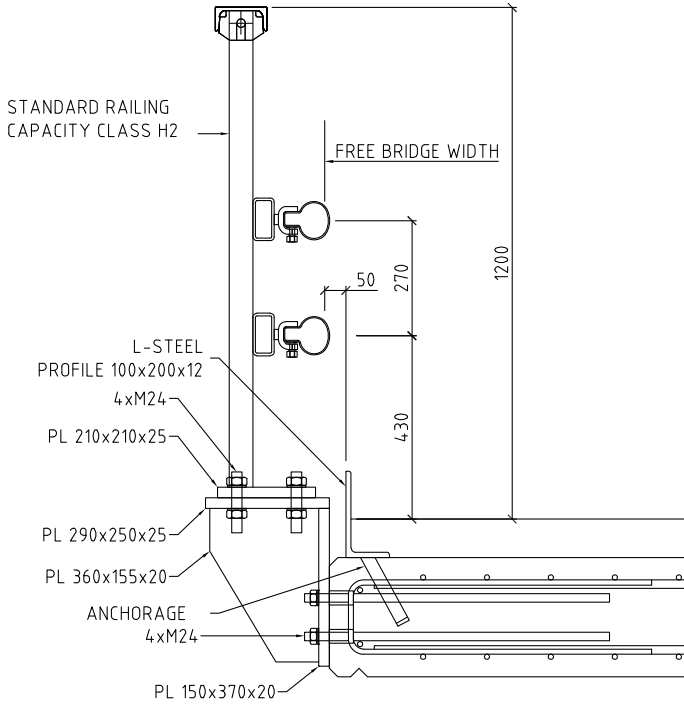

Figure 14: Group II - Without edge beam

2.5.2. Steel edge beam

A U-shaped steel edge beam is anchored from the side of the bridge deck slab. The railing posts are attached to it by bolts. The U-shaped steel edge beam is covered by a bolted external plate. Two vertical steel plates are placed at each railing post to provide stiffness. A design proposal is presented in **Figure 15**.

This type has so far not been used in Sweden. However, Trafikverket has decided to carry out a demonstration project with this solution in a real bridge in Mellösa (South of Stockholm). In this case, it will be used as a replacement for an existing damaged edge beam. Information about the project phase can be found in (Ramos, 2015). Trafikverket's intention is to make use of this alternative as a fast solution for the replacement of deteriorated edge beams in order to reduce traffic disturbances (personal communication with Trafikverket's bridge manager).

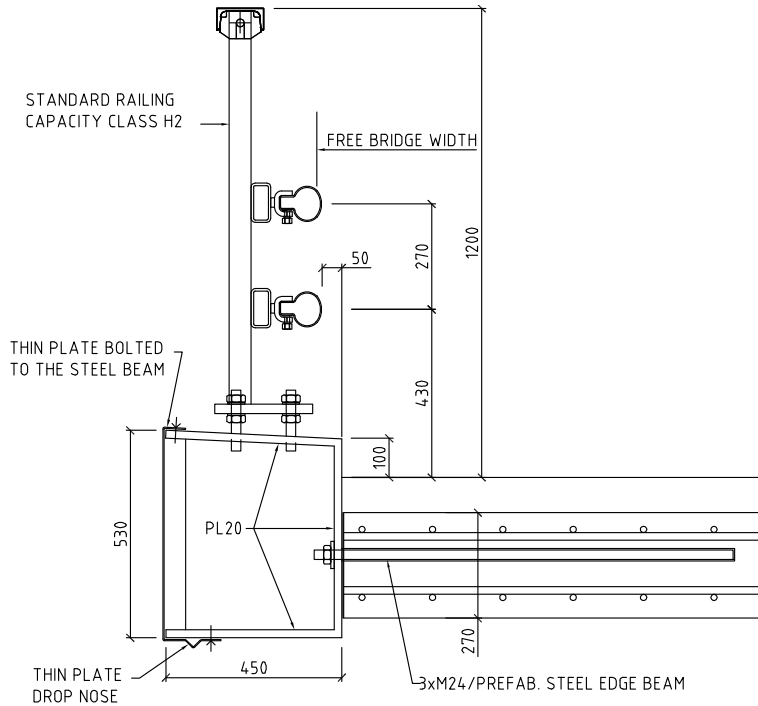

Figure 15: Group III - Steel edge beam

2.5.3. Prefabricated concrete edge beam

A typical design is shown in **Figure 16**. The construction steps are presented in **Figure 17**. The edge beam is cast *in situ*. Afterwards, it is lifted onto the bridge deck's formwork, where the resting part of the slab is cast. Eventually the edge beam is integrated. This solution is believed to have better durability. The rationale is the enhanced quality in the concrete due to favorable working conditions in comparison to the Swedish standard design. Besides, the shrinkage brought about by the deck concrete cast induces a pre-stressing effect on the edge beam. This fact results in a positive action in terms of cracking.

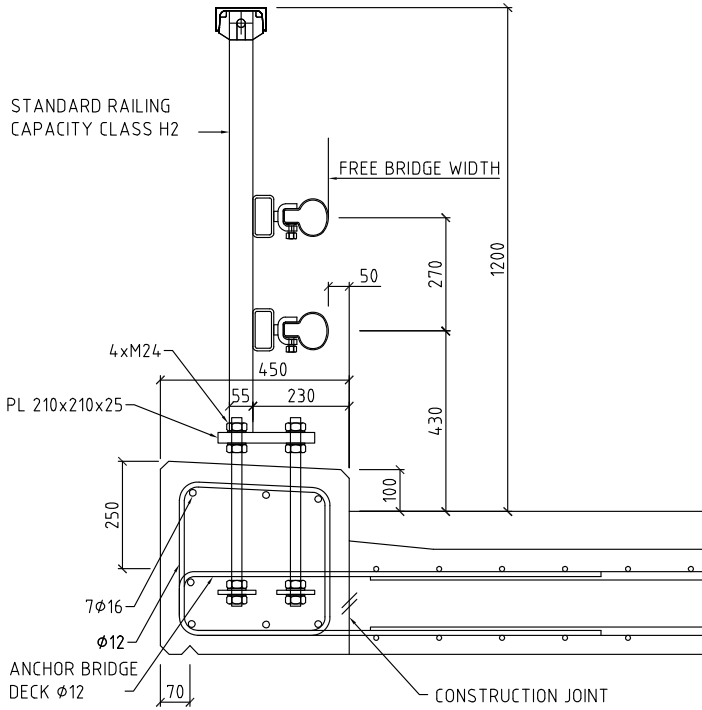

Figure 16: Group IV - Concrete prefabricated edge beam



Figure 17: Construction steps for Group IV: a) Formwork, b) Concrete pour, c) Lifting to the bridge deck slab, d) Final position before casting of the bridge deck

2.5.4. Inspection path

A variation of the aforementioned groups can be to include a so called inspection path, which can serve as a walking or cycling platform by the road and provides space for bridge inspections. A proposed design is shown in **Figure 18**.

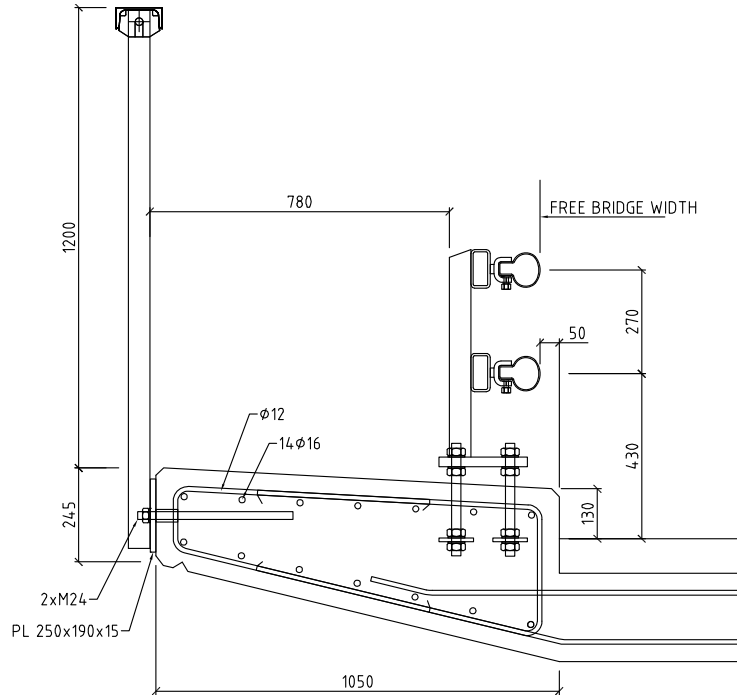

Figure 18: Group V - Edge beam with inspection path

2.6. International perspective

A large part of the research contributions concerning BEBS has lately been carried out in Sweden. Ehrengren (2000) presented a state-of-the-art inventory of edge beam designs used in countries with climates similar to that in Sweden. Troive (2008) illustrated the main functions the BEBS should fulfil along with the advantages and disadvantages of different designs. Fasheyi (2013) performed an international study where issues concerning maintenance were addressed. Several design types belonging to different countries across the world can be found in these reports. A collection of them can be found in Veganzones Muñoz (2014).

2.7. Aesthetics

The BEBS is one of the most exposed members of the bridge. Therefore, its design may be influenced by architects, especially in those bridges located in an urban area. In Switzerland, an edge beam (**Figure 19**) was designed to be used in all bridges of the light rail network connecting Zurich and the airport to be both aesthetically pleasing and distinctive (Lüthi & Zwicky, 2007).

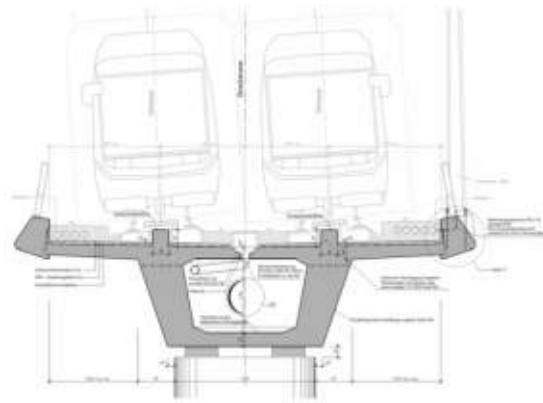

Figure 19: The cross section design of the bridge of the light rail network in the Balsberg Viaduct in Zurich (Lüthi & Zwicky, 2007).

Common design techniques to produce more attractive edge beams are listed below and visualized in **Figure 20**:

- a) Sloped edge beams, where the inclination of the edge beam produces a shining effect from the sunrays incidence.
- b) Sloped-banded edge beams, similar to the previous one, but with different inclined bands highlighting the border.
- c) Circular shaped edge beams, which provide a geometrically good-looking side view.
- d) Steel railings with different shapes and colors.

a) Concrete



a) Steel cover on concrete



b) Concrete



b) Steel cover on concrete



c) Concrete



c) Steel



d) Steel railing



d) Steel railing

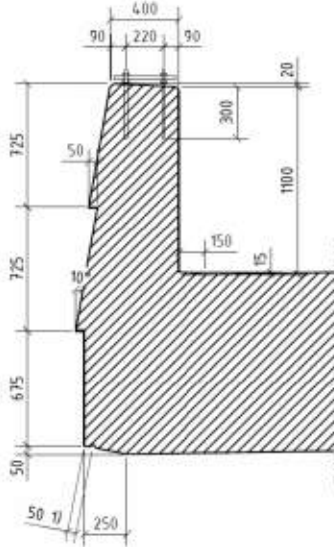

Figure 20: Design of aesthetically pleasant edge beams

Nevertheless, such designs may lead to ineffective and costly solutions (Karim, 2011). This could be the case of a landscape bridge in the north of Stockholm. The edge beams were designed in a sloped banded manner (**Figure 21a, b**). This implied additional material and labor costs, as for example the complicated formwork layout (**Figure 21b**). Besides, the fact that the edge beams had a height of 2m resulted in the decision of

placing joints in between successive concrete casts (**Figure 21d**). This way cracking from shrinkage cracks and tensile stresses on piers and abutments could be controlled. A disadvantage was that more reinforcement and more complicated forming were needed. The joint material used was extruded polystyrene foam (Kelindeman, 2014).

a) Cross sectional design



b) Edge beam during construction



c) Formwork layout



d) Joint material



Figure 21: Edge beam in the landscape bridge: a) Cross sectional design, b) Edge beam during construction, c) Formwork layout and d) Joint material (Kelindeman, 2014)

3. Life-cycle Cost Analysis

3.1. Definition and components

LCCA has been used in the procurement phase as a tool to compare a set of different design solutions and select the alternative that is better for the society in terms of costs. Bridge management systems have also made use of it to choose an optimal life-cycle strategy considering the remaining life of the structure. ISO15686-5 (2008) provides the following definition for *LCC* and *LCCA*:

Life-cycle Cost (LCC) is the *cost* of an asset, or its parts, while it fulfills its performance requirements.

Life-cycle Cost Analysis (LCCA) is a methodology for the systematic evaluation of the Life-cycle Cost over a specified period of time as defined in the agreed scope.

The different *LCC* contributions can be divided into parts as different parties in society will be either responsible for or affected by the costs occurring as a consequence of building or utilizing the structures (Sundquist & Jutila, 2007):

- Owner costs
- User costs
- Society costs
- Failure costs
- Aesthetical & Cultural values

Owner, user and society costs, and the formulae used to calculate them are presented in **Paper I**. Failure costs refer to the probability of

failure of the structure considered. For BEBSs they can be neglected since they can be considered not significant in comparison with the other contributions. Concerning aesthetical and cultural values, Safi, Du, Sundquist, & Karoumi (2013) proposed a holistic approach to consider such aspects. Even though these features can become important in the BEBS, as shown in **Section 2.7**, it has been decided not to include them as there is no widely accepted calculation method for them and their influence in the results may become more pronounced than it should. Thus, the total *LCC* in this study is expressed as (**Eq. 1**):

$$LCC = LCC_{\text{owner}} + LCC_{\text{user}} + LCC_{\text{society}} \quad (\text{Eq. 1})$$

3.2. The discount rate

The future costs along the life span of the structure are discounted by using the discount rate. The value of the discount rate is usually accounted as the real interest rate. The real interest rate is calculated from the nominal interest rate from long loans, the inflation and possible positive or negative effects on the structure (**Eq. 2**):

$$p = \frac{p_L - p_i - p_c}{1 + p_i} \quad (\text{Eq. 2})$$

Where:

- p_L is the nominal interest rate for long loans.
- p_i is the inflation.
- p_c is a factor accounting for a positive or negative effect in the structure.

The inflation is normally accounted as the one in the society obtained from the net price index. This fact has been discussed in Sundquist (2011) where it was shown that the costs in the construction sector grow more rapidly than those in society (**Figure 22**). This would result in higher inflation and lower real interest rate. On the other hand, the Swedish

State encourages Trafikverket productivity in time as means of higher discount rates.

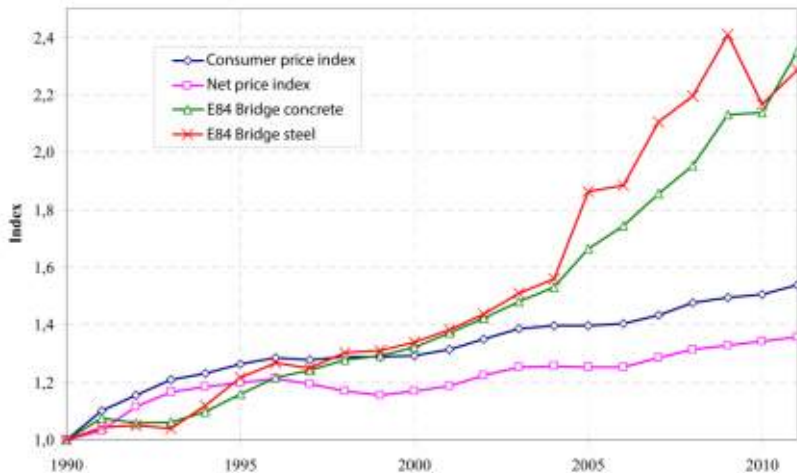

Figure 22: Comparison of the evolution of the costs according to E84 for steel and concrete structures, the consumer price index and the net price index (Sundquist, 2011).

Along the last decades the discount rate has been reduced in Sweden. In the 80s it was reduced from 8% to 5%, and in 1994 the discount rate was changed to 4%. Recently Trafikverket has announced that the recommended discount rate should be 3,5% (Trafikverket, 2015). It is a common practice in LCCA to perform a sensitivity analysis concerning the influence of different values of the discount rate on the final results.

3.3. Definition of a Life-cycle Strategy

A LCS is defined as the set of one or various life-cycle plans (LCPs) carried out at specific points throughout the life span so that the structure can fulfill its performance requirements. Each LCP contains one or several life-cycle measures (LCMs). **Figure 23** shows an example of a LCS for a structure:

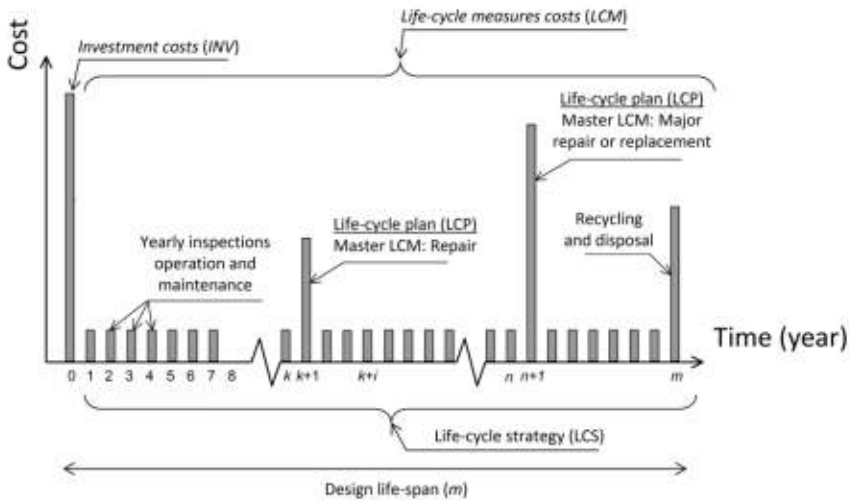

Figure 23: Example of an infrastructure's life-cycle including the LCS and the owner costs incurred along the design life span

Before performing a LCCA the LCS needs to be defined considering the bridge management process. The bridge management process refers to the series of actions or steps taken to organize and coordinate the LCMs in order for the bridge to fulfill its performance requirements. The bridge manager has to contemplate 1) whether a specific LCM must be carried out and, if so, 2) when is the adequate time for it.

Concerning the first decision, the resources available for maintenance are a critical factor. Not all bridges can be maintained. Thus, the bridge manager has to prioritize based on the condition class and the location. Bridges located in urban areas or on primary roads are generally favored (personal communication with Trafikverket bridge manager).

The user costs play an important role for the second decision. Possibilities for an enhanced planning of the LCS exist, which would lead to an improvement of the bridge management process, as an action to effectively coordinate the LCMs. A recent practice is to bundle the LCMs in LCPs in order not to perform them in successive years and cause high user costs (Adey & Hajdin, 2005; Huang & Huang, 2012; Mirzaei & Adey, 2014). This methodology is known as concurrent maintenance. Surely,

the bridge manager needs to define a safe interval within which the LCP can be carried out, so that the fact of having “delayed” LCM does not result in additional costs because of an excessive deterioration. Nishibayashi, Kanjo, & Katayama (2006) presented a diagram showing the variation of the total LCC including user costs with respect to the LCP intervals in bridges (**Figure 24a**). An excessive deterioration corresponds in this case with the left part of the curve. Not only the cost of LCMs should be considered but also the user costs incurred.

The activity of the bridge manager should not only be referred to the decision making given a condition class of one or several elements that can vary over time during the structure’s life span. This activity should also be extended “back in time” to the investment (INV) phase. In other words, design and LCC should be coupled, as is the aim of this thesis. In this regard, the trade-off between INV costs and LCMs costs is of great interest for the owner. An increased quality in the design can result in higher INV but lower LCM costs, and vice versa, shown in **Figure 24b** (Sundquist, 2011). Stainless steel can be an example for the former case. The decision of whether staying in the left part (low INV-high LCM) or the right part (high INV-low LCM) can also be conditioned by certain factors as for example the discount rate, which is discussed in **Section 3.2**.

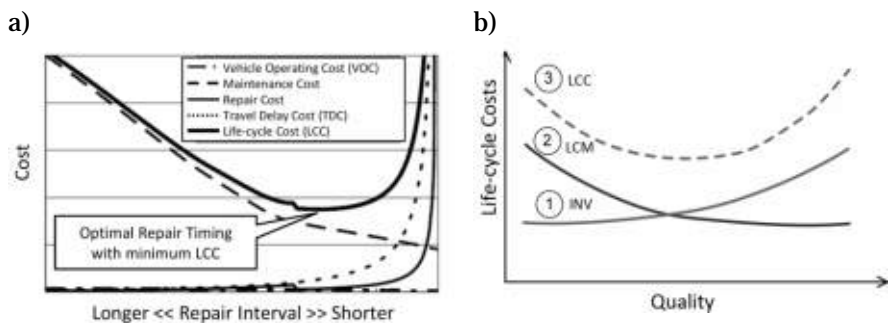

Figure 24: Schematic curves showing a) the optimal repair timing with minimum LCC, adapted from Nishibayashi et. al. (2006), and b) LCC against the quality of the structure, adapted from Sundquist (2011).

Figure 24 suggests the idea that there is an optimum balance between INV and LCM, including the LCP intervals. As explained before, longer intervals between the LCPs may lead to higher costs (left part of

the curve in **Figure 24a**). A bridge manager can wonder if an optimal strategy can be to carry out continuous short interval maintenance so that no corrective maintenance with high road disturbances is needed. In this case, the sum of numerous preventive LCMs and low associated user costs could lead to high *LCC* (right part of the curve in **Figure 24a**). The owner should with help of the bridge manager should aim to find the inflection point in the curve in **Figure 24b** in order to define an adequate LCS which would lead to the lowest total *LCC* and, hence, maximum benefit to the society.

3.4. LCCA of BEBS

3.4.1. Methodology

Paper I presents a LCCA focused only on the BEBS to evaluate and compare different design proposals in light of the costs incurred to different parties in the society. All typical Swedish bridges were grouped into different categories to perform an extensive analysis (see **Section 3.4.2**). The *LCC* calculations were performed for the representative solution of each BEBS group illustrated in **Section 2.5**. An excel-based application following the scheme depicted in **Figure 25** was developed for this purpose.

In order to provide accurate input data concerning the INV costs a Master Thesis project was carried out. Three bridge construction projects in Sweden were monitored. Material, machinery and labor cost were calculated for each construction step. LCMs information was based on information provided by the Swedish Bridge and Tunnel Management System (BaTMan) and engineering experience from the edge beam group. The parameters used for the user costs calculations are presented in **Paper I** (Veganzones, Sundquist, Pettersson, & Karoumi, 2015).

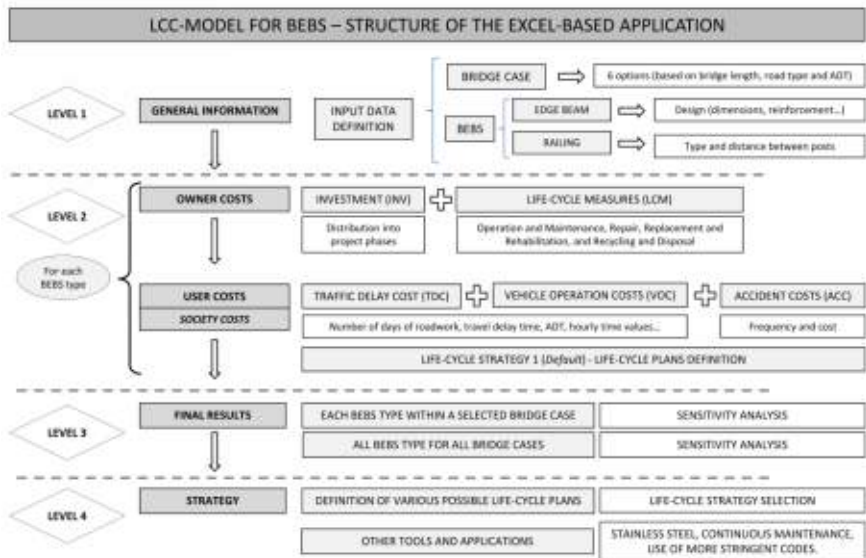

Figure 25: Structure of the LCC model and its different levels in the Excel-based application

3.4.2. Bridge cases

The division in categories can be performed according to certain parameters considered relevant to the study. In this thesis, the bridge cases have been defined according to the combination of:

- Bridge length: short (10-15 m) and long bridges (100-200 m).
- Road type: one or two lanes 3.5-m lanes with 2.0-m shoulder in each direction, and a 2.5-m median strip in the latter case.
- Urban or non-urban area: high (2,500 vehicles per lane/day) or low (10,000 vehicles per lane/day) ADT.

The reason for choosing these parameters is that, when combined, they can widely define the great majority of all existing bridge cases in Sweden. Six bridge cases have been studied (**Figure 26**). The remaining ones – long or short bridge with two lanes in each direction in a non-urban area – are excluded because their presence in Sweden is rare (Trafikverket, 2013).



Figure 26: The six bridge cases accounted in the LCCA with a Swedish bridge example for each case

3.4.3. Assumptions and limitations

LCCA should be used as a tool to evaluate and compare different alternatives. In order to perform a fair study it is paramount to identify and explain the existing assumptions and limitations. Possible sources of them when studying BEBS design solutions are listed below:

- Influence of the BEBS design on other bridge elements.
- The design life span of the BEBS and the influence of certain factors on it (see **Section 2.4.1**).
- The design life span of the bridge.
- The definition of the LCS, discussed below.
- BEBS elements included, and the influence between each other on the choice of the LCS.
- The discount rate used, see **Section 3.4.5**.
- The definition of the parameters for the user costs calculations.

3.4.4. The choice of the life-cycle strategy

In this thesis a default LCS was defined for each solution based on engineering expertise and statistical data available (Trafikverket, 2013). For the solutions that have not been constructed yet in Sweden so far – Group II and III – alternative LCSs were proposed and studied. The excel application can be used to define other different LCSs for specific bridge cases at hand. The case of continuous short interval maintenance and the limiting interval year so that such LCS could become optimal under certain assumptions for a specific bridge case can also be investigated. Such scenario analyses serve as a basis to select those solutions that could qualify for further detailed studies where the uncertain parameters are investigated.

This work refers to the *Bridge Edge Beam System*, not only to the edge beam itself. If a LCM is to be performed, Trafikverket may *take advantage* to carry out other LCMs related to other elements, that is, the practice of concurrent maintenance, as explained in **Section 3.3**. All these LCMs carried out simultaneously will constitute a LCP (**Figure 23**).

The next step is to decide the exact moment of the execution of the LCP. The approach taken in this study has been to define a governing LCM called “Master” which is the LCM that requires longer time to be executed in comparison to the resting LCMs, which are called “Slaves”.

3.4.5. Stainless steel alternatives

Enhanced durable edge beams that can survive over the life span of the bridge are an alternative option to regular maintenance. In this regard, stainless steel has lately been contemplated in order to extend the life span of the BEBS and even consider it maintenance free. Indeed, stainless steel is already required for the railing attachment to the edge beam in order to prevent corrosion in that area. To extend its use to the edge beam reinforcement is a possibility.

When considering such option, the material price of stainless steel is the principal concern of the owner. Thus, a discussion topic has been the amount of stainless steel needed in the edge beam to effectively extend its life span. In Trafikverket’s project mentioned in **Section 2.4.4** the longitudinal and transversal reinforcement and the anchorages were stainless steel (**Figure 27a**). However, the possibility of having only the transversal reinforcement stainless (**Figure 27b**) has been proposed in order to save expenses and reach the same durability (personal communication with Valbruna Stainless and Swerea KIMAB). The rationale is that it is sufficient to protect the area closest to the external environment, which in this case would correspond to the outer reinforcement layer i.e. the transversal reinforcement.

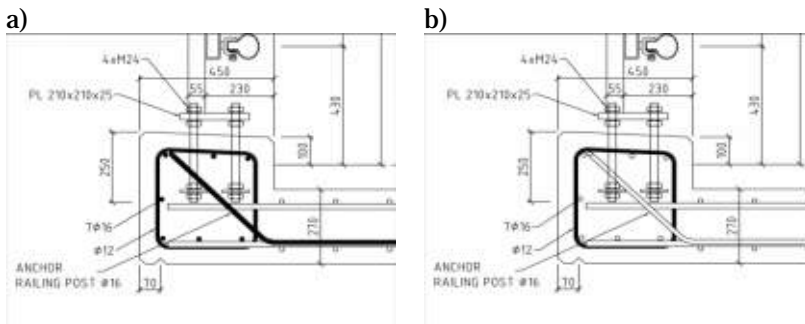
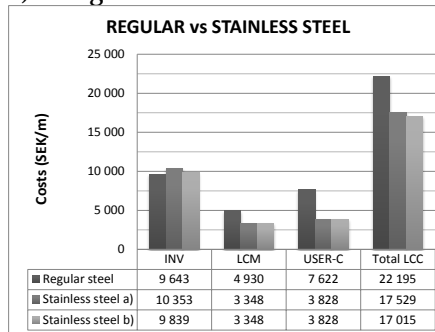

Figure 27: Design solutions with stainless steel in a) the transversal reinforcement only, and b) the transversal and longitudinal reinforcement, and the anchorage.

A LCCA analysis was performed for both design alternatives for bridge case 1 and 6 (**Figure 28**). The results show that both stainless steel alternatives can become up to 20% and 40% better in terms of *LCC* for bridge cases 1 and 6, respectively. A slight difference in the INV cost is appreciated between the two stainless steel designs.

a) Bridge case 1



b) Bridge case 6

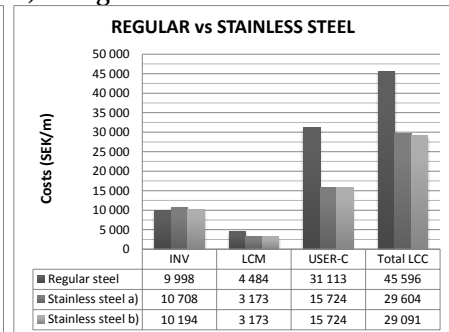

Figure 28: LCC comparison for a solution with regular steel, full reinforced stainless steel and only transversal reinforced stainless steel for a) Bridge Case 1 and b) Bridge Case 6.

Stainless steel can also be used in other solution proposals from the edge beam group. This has for example been for the steel edge beam solution which is going to be first implemented on a real bridge in spring 2016. Apart from extending the life span, to use stainless steel was motivated by the presence of a railway track underneath. A detailed description of the design phase was presented by Ramos (2015).

3.4.6. The influence of the discount rate

Figure 29 displays the influence of discounts rates from 2.0% up to 7.0% on the LCM costs, UC and LCC for bridge case 3. These values have been chosen since they are within a common interval in industrialized countries (Salokangas, 2009; Thoft-Christensen, 2011). Low discount rates lead to higher total *LCC*, whereas higher discount rates result in lower total *LCC*. A variation of 3-4 times the value of the total *LCC* was observed.

The discount rate also influences the decision of choosing stainless steel to be used in the BEBS. **Figure 30** shows a sensitivity analysis car-

ried out for Type I for bridge case 6 where the discount rate is varied from 2.00% to 7.00%. High discount rates lead to an almost negligible difference in terms of *LCC*. However, for low discount rates, the use of stainless steel leads to a considerable lower *LCC*. Hence, lower values of the discount rate encourage the use of better quality materials that can reduce the LCM costs incurred along the bridge’s life span.

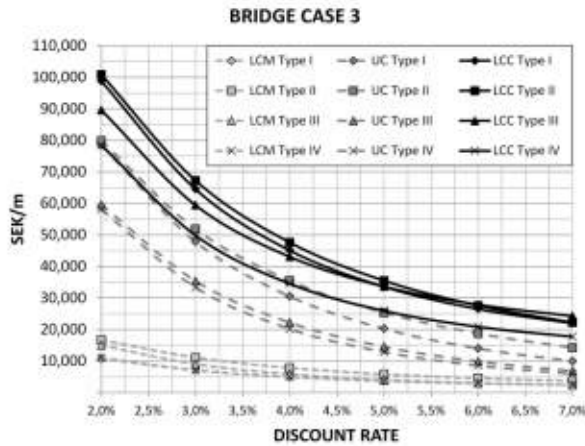

Figure 29: Influence of the discount rate on the LCM costs, user costs and *LCC*



Figure 30: The influence of the interest rest on the total *LCC* for bridge case 6 using the design solution Type I with regular steel and with stainless steel

3.5. Summary

- LCCA is a tool that can be used for the development of new BEBS solutions that can be better for the society in terms of cost in order to evaluate and compare them. Such methodology allows taking into consideration the cost contribution from different parties that are involved throughout the life span of the structure. From this assessment it can be concluded which alternatives can qualify for further detailed studies.
- The importance of the definition of an adequate LCS for the bridge case at hand during the preliminary design. Concurrent maintenance schemes that group LCMs into LCPs allow for the reduction of user costs. A governing “Master” LCM can be chosen to decide on the execution time of a LCP.
- For long bridges the concrete integrated edge beam (Type I) may be a good solution whereas for short bridges the prefabricated edge beam (Type IV) may be a good solution. Uncertainties related to Type II and III exist. A scenario analysis shows that under certain assumptions these solutions may become better from a LCCA perspective. Thus, these solutions are proposed for thorough study and subsequent implementation in a real bridge project. Structural design aspects should also be considered.
- Stainless steel can be used to extend the design life span of the BEBS. This material can be used in all design proposals presented. The total LCC is shown to be lower in comparison to a design solution with normal steel because of the LCM costs and, especially, the user costs.
- The discount rate is usually accounted as the real interest rate. The recommended value in Sweden by Trafikverket is 3.5%. The influence of this value on the total LCC is addressed by sensitivity analyses, as a common practice in LCCA. A low value of the discount rate encourages the investment in better quality solutions (high INV costs) that do not require important maintenance (low LCM costs) during the life span.

4. Structural analysis

4.1. The role of the edge beam

The design of edge beams might be influenced by different factors that actually are non-related to structural behavior. One such factor is aesthetics as explained in **Section 2.7**. Even though it is not a roadway bridge, an interesting case to mention was an investigation of concrete cracks in a railway composite bridge with very big edge beams carried out by Ansnaes & Elgazzar (2012) (**Figure 31**). The thesis motivated that the cracks observed in the edge beams were because these were behaving as a load-carrying member due to its considerable cross-sectional size, in comparison to the rest of the deck slab. Nevertheless, the edge beams had not been designed for that purpose. It was stated that the reinforcement ratio to limit the crack width should have been increased.

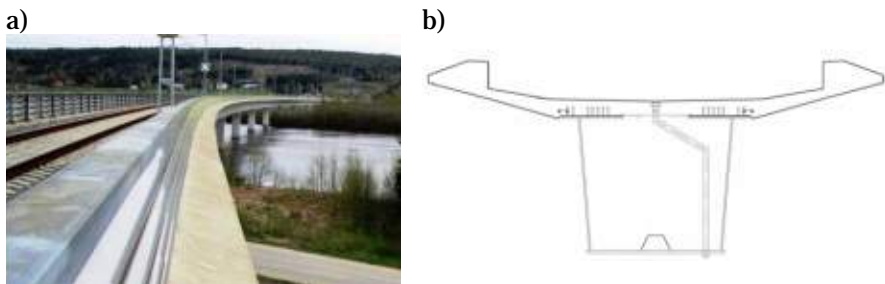

Figure 31: Cross section of the Ångermanälven bridge (Ansnaes & Elgazzar, 2012).

The railing type may also condition the edge beam design. This was the case for the two bridges in Rotebro where the use of high containment level H4 railings led to bigger edge beams than usual ($470 \times 565 \text{ mm}^2$). In the eastern bridge the initial number of longitudinal rebars was increased from 9 to 11 (Kelindeman, 2014). However, because of the cracks that appeared after construction, it was decided subsequently to further in-

crease to 13 longitudinal rebars in the western bridge. Another feature in the solution is the substitution of the drip groove (drop nose) at the bottom surface for a longer inwards and outwards sloped area (**Figure 32**).

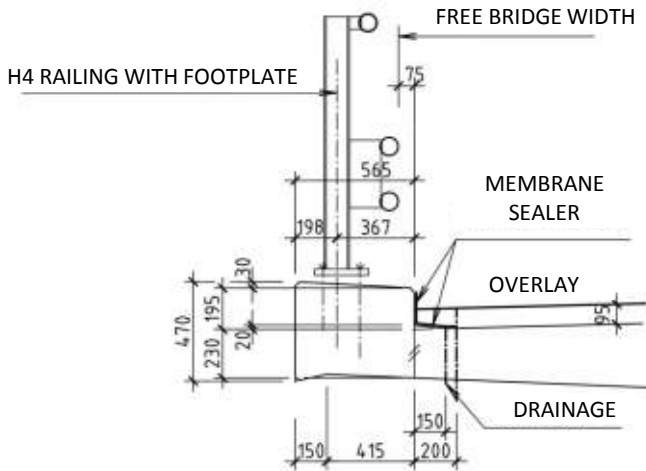

Figure 32: Cross sectional design of the Rotebro bridge

The dimensions of the edge beam do affect the structural behavior of the bridge deck slab. The study of this influence is paramount for the development of the BEBS type II and III, where such load-carrying contribution does not exist. Smith & Mikelsteins (1988) demonstrated the influence of edge stiffened slabs on slab-on-girder bridges on the load distribution as means of deflection and moments, and suggested that a refined method of analysis which includes the edge stiffening effect.

Vaz Rodrigues R. (2007) investigated the influence of edge beam sizes (including without edge beam) on the bending moment and shear force distributions with a linear-elastic FE-analysis in a cantilever slab. The self-weight was not included. A smooth reduction of the shear forces was observed at the overhang support and the perimeter around the loads closer to the root. In contrast, the shear forces at the perimeter around the loads within the slab close to the free edge were of a considerable lower magnitude. The presence of an edge beam was contributing to transfer the load in the longitudinal direction and providing a wider distribution of the shear forces.

A smooth reduction of the magnitude of the bending moment at the root of the cantilever was reported for larger edge beams. Duran (2014) studied this effect in a bridge case study in Stockholm for the load models defined in the Eurocode. The addition of the self-weight resulted in lower bending moment for the case without edge beam. This enables investigate the limit where having an edge beam can affect positively or negatively the flexural resistance. The factors governing this effect would be the size of the edge beam and the span of the overhang.

Klowak, Mufti, & Bakht (2010) investigated the hypothesis of arching-action in stiffened bridge deck cantilever slab overhangs subjected to static and fatigue concentrated loads. A large edge beam acting as a barrier was considered. A laboratory test with a full-scale bridge deck showed evidence of such arching-action which would mean a break-through in cantilever behavior when subjected to a concentrated load (ibid). Further studies are ongoing.

4.2. Swedish codes

In Sweden the bridge technical regulations called Bro 11 is published by Trafikverket and divided into two parts: Requirements –“TRVK Tekniska Krav”–, (Trafikverket, 2011a) and Recommendations –“TRVR Tekniska Råd”–, (Trafikverket, 2011b). Aspects considered relevant for the BEBS are presented below.

4.2.1. Requirements in Bro 11 (TRVK)

Concerning the edge beam (Bro 11, principally sections B and D):

- A drip groove ('drop nose') must be provided (B.1.11.1).
- The height over the overlay and the horizontal distance between the railing and the inner part of the edge beam must be the same as the edge beam corresponding to the crash test (B.1.11.2).
- In bridge deck slabs over roads, railway tracks, water bodies, etc. the height over the overlay must be at least of 80 mm. to facilitate the drainage of water (B.1.11.2).

- In the wing walls the design will be the same as in the superstructure of the bridge. The edge beam should have an insulation layer (D.1.2.4.2).
- The reinforcement must ensure a good crack distribution (D.1.2.4.6).
- Connections to the reinforcement for the measurement of the electrical potential must be provided. The maximum distance allowed between two different measuring points is 100 m. (D.1.4.2.2).
- For the calculation of forces and moments in the direction of the main girder, the edge beam plus 100 mm. inside the bridge deck slab must not be accounted for in the contributing flange width. The rationale is that the bridge overhang must be designed so it can stand while there is a replacement of the edge beam. A traffic load placed at a distance of 1 m. from the edge beam's inner side should be used for the structural resistance verification. The influence of the edge beam on the overall stiffness may not be considered (D.2.2.1.2).
- If the pavement requires support, the edge beam may not be designed as a non-raised edge beam (G.3.2.6).

Concerning the railing (mainly section G.9):

- The design must be carried out according to SS-EN 1317-5. The requirements concerning the capacity class H2 and the injury risk class B according to SS-EN 1317-2 must be fulfilled (G.9.1.1).
- The height over the overlay to the top chord must be of at least 1100 mm (G.9.1.2.1).
- The free opening between the edge beam top edge and the middle railing and between the middle railing and the top chord must not be over 450 mm. If this is not fulfilled an additional middle railing must be placed (G.9.1.2.1).
- The verification of the railing attachment must be calculated according to SS-EN 1991-2, 4.7.3.3(2).
- Other details of the railing can be checked in section G.9.1.6.

Concerning the drainage system (principally section G.5):

- The drainage pipe will be built in the lowest part of the bridge deck slab towards the edge beam or the ground drainage hole (G.3.2.10).

Some requirements of the lighting poles are listed below:

- A drip groove ('drop nose') must be provided.
- The design must allow for an adequate drainage so that the water does not accumulate.

Requirements concerning other secondary elements in the bridge edge beam system can be found in section G.12.

4.2.2. Recommendations in Bro 11

Concerning the edge beam:

- A raised edge beam should have a slope inwards the bridge deck slab of at least 1:20. For the rest of edge beam types a slope outwards the bridge deck slab of at least 1:20 should be provided.
- The thickness of the bridge deck slab in a road bridge should be of at least 170 mm (D.1.2.6).
- The edge beam should be designed with an adequate height and width so that a good concentrated load distribution is provided (D.1.2.7.3).
- The edge beam should be designed so that the resistance and the measures of the railing attachment are adequate. In a road bridge the minimum dimensions are 400 x 400 mm². The anchorage corresponding to the railing should be accounted for in the reinforcement calculations (D.1.2.7.3).
- The exposure class in a road bridge should be of XD3 or XF4.
- The longitudinal reinforcement should be of at least 7Ø16. In case of bridge overhangs more reinforcement is usually needed. The minimum reinforcement in the edge beam should be distributed in the following way (D.1.4.1.6):
 - 2 bars in the upper outer corner.
 - 2 bars in the upper inner corner.
 - 1 bar in the middle outer side.

- 2 bars in the bottom part (1 bar in each corner).
- The transversal reinforcement should be of at least $\varnothing 10$ s 300 mm. The anchorage should be of at least $\varnothing 16$ mm (D.1.4.1.6).
- The electrical contact between the reinforcement and the railing can lead to corrosion taking place in the latter. This should be checked through the electrical potential connections. However, in a bridge of an electrified railway track the control should show that there is an electrical contact with the railing (D.1.4.2).

Concerning the railing:

- The railing may be designing when deciding on the cross-section and length of the edge beam (B.1.12.2).

Recommendations about the drainage system are found in section B.1.10.1. With respect to other secondary elements, recommendations for the lighting poles can be found in Bro 11 Section G.

4.3. Design of bridge deck cantilever slabs

Normally bridge deck overhangs are geometrically designed with a tapered thickness across the concrete slab decreasing from the root towards the free edge ending in an edge beam. For a structural analysis bridge overhangs slabs in beam bridges with a box cross section, or those where a concrete slab lies on steel or concrete girders (**Figure 33**) may be designed by treating them as cantilever slabs in isolation without any appreciable loss of accuracy (Bakht, 1981). However, such assumption of full fixity should be handled with care because it might lead to conservative estimates, as explained later on.

The generic problem is described as a concentrated load – or a group of them – acting at an arbitrary point of the bridge deck overhang slab (**Figure 33**). A multi-level assessment of RC bridge deck slabs was proposed by Plos, Shu, Zandi, & Lundgren (2015):

- Level I: Classical simplified methods (traditional approach)
- Level II: 3D linear shell FE-analysis (current approach)
- Level III: 3D non-linear shell FE-analysis

- Levels IV and V: 3D non-linear continuum analysis, depending on the modeling of the bonding of the reinforcement.

Classical simplified calculations may be suitable for its use at the design office instead of a FE-model, or alternatively to control the results if a FE-model was developed. A two-step procedure with a sectional analysis is followed. For a RC cantilever slab, 1) the design transversal bending moment per unit width along x-axis $m_{y,d}$ and the design shear force per unit width v_d along the the critical cross section considered are calculated and 2) verified against the corresponding resisting capacity. The flexural and shear criteria are explained below. The longitudinal bending moment $M_{x,d}(x)$ in the edge beam should also be checked, and a crack control needs to be included. Non-linear analyses allow for the calculation of the load capacity Q_{Rd} . In level IV a verification of the anchorage should be performed and in level III a shear/punching verification is additionally needed. Level V is a purely one-step procedure as the previous tasks are already reflected in the analysis.

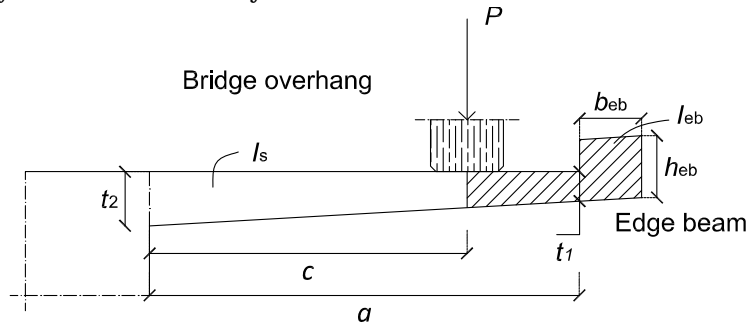

Figure 33: Generic problem of a concentrated load applied on a bridge deck overhang slab

4.4. Flexural criterion

The exact solution to the problem of a cantilever slab with a concentrated load arbitrarily applied was traditionally pursued by designers. A time-line review of the development of classical simplified hand-calculation methods to derive $m_{y,d}$ and $M_{x,d}$ is presented. These methods are lower-bound and based on the theory of elasticity. A moment field is considered a lower bound if a) it is in equilibrium and b) the moments at all points of the structure are smaller than the corresponding yielding moments. The load corresponding to that moment field is always smaller

or equal to the actual failure load. Upper-bound methods can also be used; the reader is referred to (Lu, 2004) for a detailed description. The notation used is illustrated in **Figure 34**.

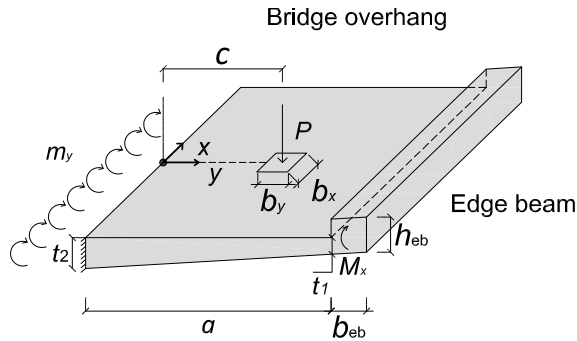

Figure 34: Notation used for the flexural criterion of a bridge overhang slab structurally idealized as a cantilever slab

4.4.1. Simplified calculation methods

- ***Beam theory based***

Wästlund (1964)

The generic problem is formulated as a beam on elastic foundation that refers to the concrete slab divided into strips. The model presumes that the concentrated load P is acting on the edge beam. **Eq. 3-4** express the formulation to derive m_y and $M_x(x)$. The maximum value of $m_y(x)$ is reached at $x = 0$ (**Eq. 6**). The maximum and minimum value of $M_x(x)$ is reached at $x = 0$ and $x/a = \pi/(2\lambda a)$ respectively (**Eq. 7-8**). λ is a parameter that depends on the moment of inertia per unit length of the plate strip i_y , the moment of inertia of the edge beam I_{eb} and a factor accounting for a tapered thickness k_t . A chart with values of the latter parameter can be found in Sundquist (2011).

$$m_y(x) = \frac{\lambda P a}{2} e^{-\lambda x} (\cos \lambda x + \sin \lambda x) \quad (\text{Eq. 3})$$

$$M_x(x) = \frac{P}{4\lambda} e^{-\lambda x} (\cos \lambda x - \sin \lambda x) \quad (\text{Eq. 4})$$

$$\lambda = \frac{3k_t l_y}{4a^3 I_{eb}} \quad (\text{Eq. 5})$$

$$m_{y,\max} = m_{y,d} = \frac{\lambda Pa}{2} \quad (\text{Eq. 6})$$

$$M_{x,\max} = M_{x,d1} = \frac{Pa}{4\lambda a} \quad (\text{Eq. 7})$$

$$M_{x,\min} = M_{x,d2} = -\frac{0,052}{\lambda a} \quad (\text{Eq. 8})$$

- **Plate theory based**

Jaramillo (1950)

Jaramillo (1950) presented an exact solution in terms of proper integrals for $m_y(x)$ due to a concentrated load acting at an arbitrary point of an infinitely long cantilever plate of constant width and thickness. The solution is derived by plate theory and is transformed into series form by means of contour integration, and is illustrated by numerical examples.

Pucher (1951) and Homberg & Ropers (1965)

Pucher (1951) presented influence surfaces for the calculation of $m_{y,d}$ at the root of the bridge overhang for constant thickness slabs. They are based on classical plate theory assuming small deflections and no shear deformations. Homberg & Ropers (1965) extended this work by including variable thicknesses (linear and parabolic) and multiple spans including cantilevers. **Figure 35** shows an example of an influence surface for a root-free edge thickness ratio $t_2/t_1 = 2$. The effect of the edge beam may be accounted for by extending the concrete slab with a portion equivalent to the flexural rigidity of the edge beam. This approach should be handled with care since it might lead to inaccurate results if the flexural rigidity is not small compared to that of the slab.

To calculate $m_{y,max}$ the concentrated load P is placed on the application point of the concrete slab of **Figure 35**, using the corresponding scale to the slab represented. The influence surface that matches with this location will indicate the coefficient f used in **Eq. 9**. In case of multiple n loads, several coefficients f_n can be used for each (**Eq. 10**). Multiple positions of the load with respect the symmetry line in order to find the most critical case should be contemplated.

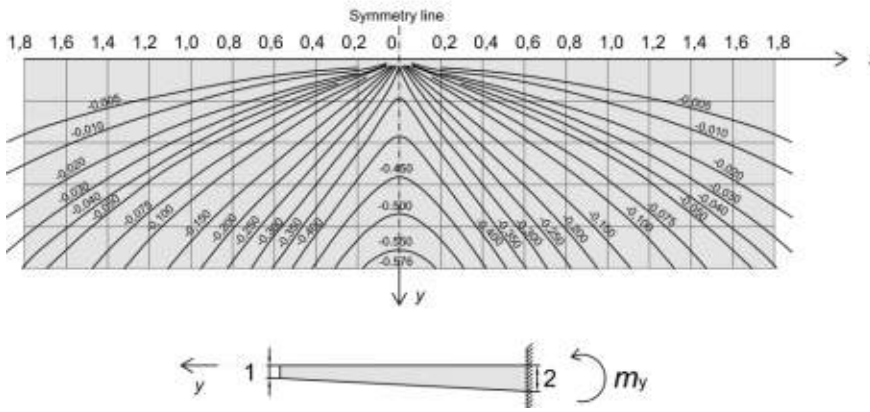

Figure 35: Example of an influence surface for the calculation of $m_{y,max}$ for a thickness variation of $t_2/t_1 = 1/2$. Reproduced from Homberg & Ropers (1965)

$$m_{y,max} = m_{y,d} = f P \tag{Eq. 9}$$

$$m_{y,max} = m_{y,d} = \sum_{i=0}^n f_n P_n \tag{Eq. 10}$$

Reismann & Cheng (1970)

Reismann & Cheng (1970) presented a solution for a cantilever plate strip reinforced by a beam bonded to its free edge and clamped to the opposite parallel edge. A concentrated load P is applied on the edge beam. Beam/plate stiffness ratios in bending and torsion are introduced. The results are expressed in terms of improper integrals and are evaluated by a numerical integration procedure. A solution without an edge

beam is also presented, which leads to the same results obtained by Jaramillo (1950).

Sundquist (2010)

Sundquist (2010) avoided the use of improper integrals in the problem by assuming the transversal free edges of the cantilever to be simply supported. An analytical solution using plate theory of a finite cantilever slab of a length L with an edge beam subjected by a concentrated load P was presented to calculate $m_{y,\max}$ and $M_{x,\max}$ (Eq. 11-12). The calculation of the parameters B_k , α_k , D_k and t are explained in Sundquist (2008), and depend on the flexural rigidity (D) of the plate, the elastic modulus of concrete (E_c) and the moment of inertia of the edge beam (I_{eb}). Sundquist (2010) also showed that Wästlund's solution using beam theory was more conservative compared to his solution based on plate-theory. A drawback from using these solutions is that the load shall be placed on the edge beam and not in the slab. A possibility for avoid this limitation could be to consider the part of the slab located from the load application point to the free edge as an edge beam. This option nevertheless would not be suitable for loads close to the root of the overhang.

$$\frac{m_{y,\max}}{P} = \sum_{k=1,2,\dots}^{\infty} a^2 \alpha_k^2 B_k 2 \sin \frac{\alpha_k L}{2} \quad (\text{Eq. 11})$$

$$\begin{aligned} \frac{M_{x,\max}}{Pb} = \frac{E_c I_{eb}}{Db} \left(\frac{a}{L}\right)^2 \sum_{k=1,2,\dots}^{\infty} (k\pi)^2 [B_k \sinh t \\ + D_k (-\sinh t + t \cosh t)] \sin \frac{\alpha_k L}{2} \end{aligned} \quad (\text{Eq. 12})$$

- FE-model based

Bakht & Holland (1976)

Bakht & Holland (1976) presented a semi-graphical simplified solution for the elastic analysis of wide cantilever slabs of linearly varying thickness based on the equations derived by Sawko & Mills (1971). A distribution of the transversal moment $m_y(x)$ at any point of the cantilever slab can be derived (Eq. 13). Coefficients A' are obtained from tables which depend on the ratio of thicknesses t_2/t_1 , the relative position of the load

c/a and the reference station $B = x/a$. Such coefficients were calculated from a FE-model by satisfying **Eq. 13**. Jaeger, L.-G., & Bakht (1990) re-wrote **Eq. 11** as an algebraic function from a linear elastic solution (**Eq. 14**). This equation is currently used by Canadian codes (Canadian Standards Association, 2015). This approach would be more justifiable for steel plates but in fact it is a safe side approximation for cracked concrete.

$$m_y(x, y) = \frac{P}{\pi} A' \frac{1}{\cosh\left(\frac{A'y}{c-x}\right)} \quad (\text{Eq. 13})$$

$$m_y(x, y) = \frac{P}{\pi} A' \frac{(c-y)^4}{[(c-y)^2 - (A'x/2)^2]^2} \quad (\text{Eq. 14})$$

$$m_{y,max} = m_{y,d} = m_y(0,0) = \frac{P}{\pi} A' \rightarrow A' = \frac{m_y(0,0) \cdot \pi}{P} \quad (\text{Eq. 15})$$

The presence of an edge beam was considered following the same approach. A non-dimensional parameter in terms of plate/edge beam stiffness ratios (I_{eb}/I_s) was added to the tables to obtain new values of A' (**Figure 36**). Bakht (1981) also introduced an expression to calculate the maximum sagging and hogging for the edge beam M_x using coefficients that can be obtained from a similar graph that depends on the values of t_2/t_1 , c/a , and I_{eb}/I_s . A solution for semi-infinite wide cantilever slabs with a similar procedure was also presented (Bakht, 1981).

Dilger, Tadros, & Chebib (1990)

The assumption of full fixity at the clamped edge was studied by Dilger, Tadros, & Chebib (1990). A comparison through a FE-analysis of a bridge overhang modelled as a cantilever in isolation, and together with the webs and the top and bottom slabs was presented. It was shown that, for relatively thin and deep webs, transversal bending moments higher by up to 40% were obtained if the slab was structurally idealized as a cantilever. The flexible restraint provided smaller moments at the root, especially for short overhang spans and loads very close to the support. A new parameter $S^* = 4a/l$ was introduced to represent the elastic restraint, where l is the length of the internal portion of the slab. Similar design charts to obtain A' were presented (**Figure 37**). A case of $S^* = \infty$ means a

rigid restraint and corresponds to the cases presented by Bakht & Holland (1976).

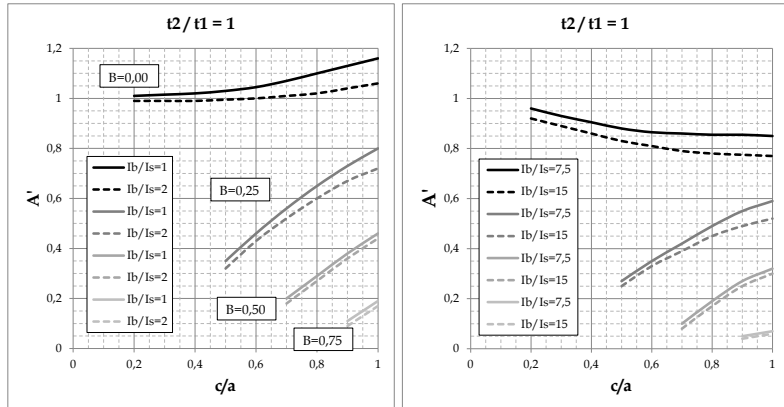

Figure 36: Design chart for the coefficients A' depending on or different thickness ratios t_2/t_1 , relative distance of the load application point with respect to the root of the overhang c/a , the reference stations x/a , and the ratio of plate/edge beam moment of inertia l_{eb}/I_s . Adapted from Bakht & Holland (1976)

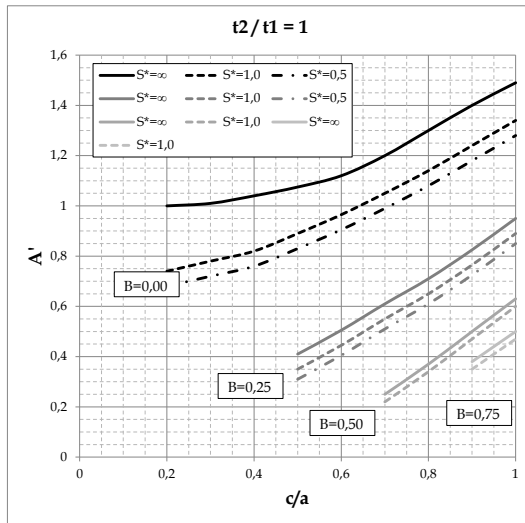

Figure 37: Design chart for the coefficients A' for a thickness ratio of $t_2/t_1 = 1$, relative distance of the load application point with respect to the root of the overhang c/a , the reference stations $B = x/a$, the ratio of plate/edge beam moment of inertia l_{eb}/I_s and the parameter S^* . Adapted from Dilger et. al. (1990)

Mufti, Bakht & Jaeger (1993)

Mufti, Bakht, & Jaeger (1993) extended the previous work to analyze as well hogging moments in internal deck slab panels as well. If the overhangs are stiffened by an edge beam the authors suggested extending the overhang by an equivalent portion with the same flexural rigidity. The cantilever was assumed to have infinite width. For loads near the transverse free edge it was suggested to use a factor of 2 to obtain the bending moment.

4.4.2. FE-calculations and distribution widths

The Eurocode (CEN [European Committee for Standardization], 1998) provide a graphical calculation of the plastic rotation capacity for different compression height-effective depth ratios x_u/d . It is stated that moments achieved through linear elastic analysis and linear FE-analysis may be redistributed, provided that the resulting distribution remains in equilibrium with the applied loads. However, there is no clear formulation for the distribution widths (w_m). Designers usually account for the maximum m_y obtained from the FE-model, which may lead to conservative estimates. Pacoste, Plos, & Johansson (2012) proposed recommendations for the calculation of the distribution width, denoted here as $w_{m,PPJ}$ (Eq. 16). For loading situations involving two forces a wider distribution width (w_{mR}) can be used according to Eq. 15 and Figure 38.

$$w_m = w_{m,PPJ} = \begin{cases} \min \begin{cases} 7d + b_x + t_p & \text{for } \begin{cases} 0,25 \geq \frac{x_u}{d} \geq 0,15 & \text{for concrete classes } < \frac{C55}{67} \\ 0,15 \geq \frac{x_u}{d} \geq 0,10 & \text{for concrete classes } \geq \frac{C55}{67} \end{cases} \\ 10d + 1,3y_{cs} \end{cases} \\ 2h + b + t_p & \text{for values of } \frac{x_u}{d} \text{ outside the above limits} \end{cases} \quad (\text{Eq. 16})$$

$$w_{m,R} = 2x_R + w_m \quad (\text{Eq. 17})$$

- d is the effective height of the cross section studied,
- b_x is the width of the load,
- t_p is the thickness of the overlay,
- y_{cs} is the distance from the center of the load application to the critical cross section

- x_u is the depth of the neutral axis at the ultimate limit state after redistribution (should be evaluated for the section with the highest reinforcement ratio).

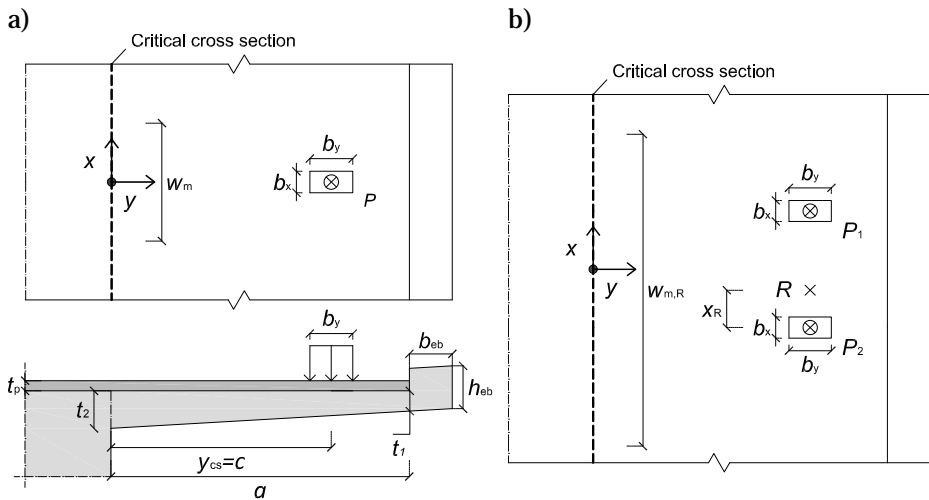

Figure 38: Distribution width for the bending moment for a) one concentrated load b) and two concentrated loads

4.5. Shear criterion

4.5.1. Simplified calculation methods

Two types shear brittle failure modes are traditionally identified: one-way shear and two-way shear (punching). One-way shear is related to line loads and linear supports. Two-way shear is associated to concentrated loads. In bridge deck cantilever slabs a mixture of both has been documented according to experimental tests, which are described later. Thus, both one-way and two-way shear design criteria should be adopted.

- One-way shear (**Eq. 18**):

$$v_d = v_Q + v_{SW} + v_{pav} + v_{perm} < v_{Rd} \text{ [kN/m]} \quad (\text{Eq. 18})$$

$$v_Q = \frac{Q_d}{w_{s,B11}} \text{ [kN/m]} \tag{Eq. 19}$$

Where:

- v_Q is the shear force per unit length due to a (group of) concentrated load(s), calculated from **Eq. 19**.
- v_{SW} is the shear force per unit width due to the self-weight.
- v_{pav} is the shear force per unit width due to the overlay.
- v_{perm} is the shear force per unit width due to the other permanent loads.
- $w_{s,B11}$ is the distribution width for shear calculated according to Bro 11 (**Eq. 20**). **Figure 39** illustrates the calculation of $w_{s,B11}$ for a concentrated load. For two concentrated loads the principle illustrated in **Figure 38b** applies. **Figure 39b** shows an example for four concentrated loads.

$$w_{s,B11} = \max \left\{ \begin{array}{l} 7d + b_x + t_p \\ 10d + 1,3y_{cs} \end{array} \right. \tag{Eq. 20}$$

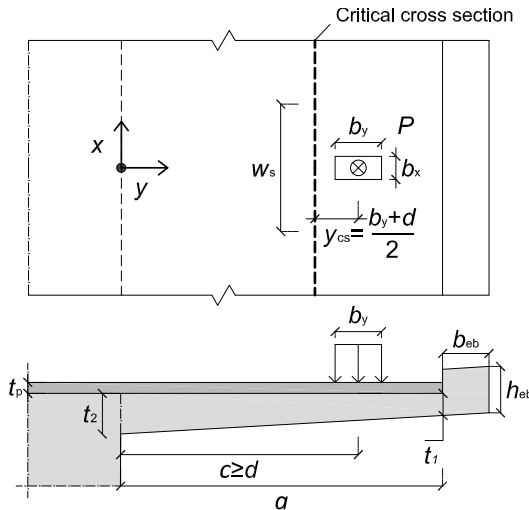

Figure 39a: Distribution width for the shear force for a) one concentrated load

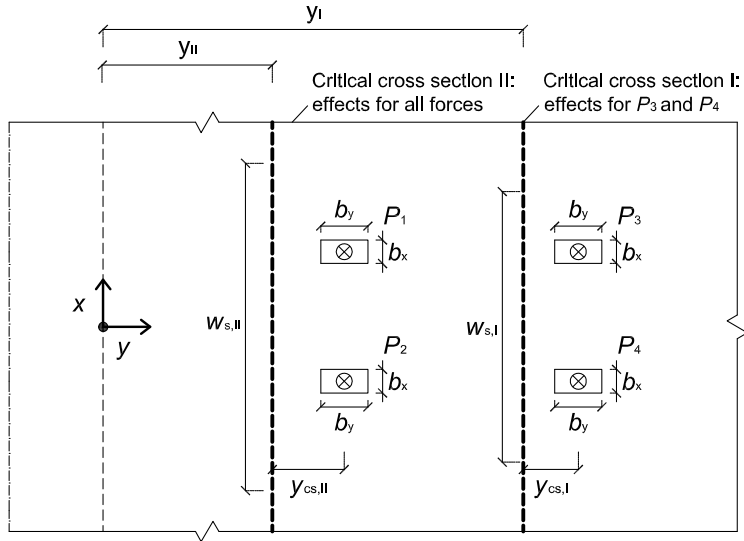

Figure 39b: Distribution width for the shear force for a) one concentrated load and b) multiple concentrated loads

- Two-way shear – punching (**Eq. 21**):

A three-sided control perimeter (w_p) around the concentrated loads leaving the side closest to the free edge can be used for RC overhang slabs (Vaz Rodrigues, Fernández Ruiz, & Muttoni, 2008). The value of w_p could be calculated following **Figure 40**. According to Eurocode and ACI the distance from the load application should be $2d$ and $d/2$, respectively. Since this approach may result conservative, Vaz Rodrigues R. (2007) proposed instead to calculate w_p using the maximum principal shear obtained from a linear-elastic FE-analysis ($v_{FE,max}$) and the flexural load capacity ($Q_{m,Rd}$) calculated from a simplified method (**Eq. 23**).

$$v_d = v_Q + v_{SW} + v_{pav} + v_{perm} < v_{Rd} \text{ [kN/m]} \quad (\text{Eq. 21})$$

$$v_Q = \frac{Q_d}{w_p} \text{ [kN/m]} \quad (\text{Eq. 22})$$

$$w_p = \frac{Q_{m,Rd}}{v_{FE,max}} \quad (\text{Eq. 23})$$

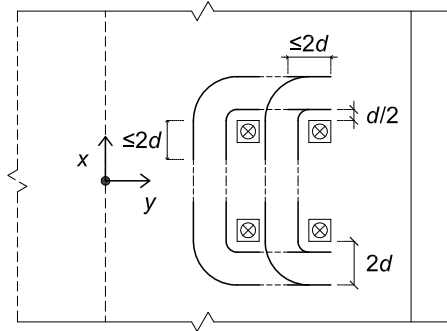

Figure 40: Definition of a three-sided control perimeter for a group of four concentrated loads

4.5.2. FE-calculations and distribution widths

- One-way shear:

The principal shear force v_0 from the shear forces in x and y -directions obtained from the FE-model should be considered (Eq. 24). The distribution widths according to Bro 11 ($w_{s,B11}$) are calculated according to (Eq. 25). Pacoste et. al. (2012) have recently proposed refined recommendations, denoted here as $w_{s,PPJ}$ (Eq. 26). For a certain load position, a linear interpolation between the maximum ($w_{s,max}$) and minimum ($w_{s,min}$) distribution widths should be performed (Figure 41). The minimum is restricted by a distance a_{min} from the railing. A limiting condition for the calculation of an effective distribution width $w_{s,eff}$ is illustrated in Figure 42. The motivation for this is to account for only those shear forces that are carried in the y -direction.

$$v_0 = \sqrt{v_x^2 + v_y^2} \tag{Eq. 24}$$

$$w_{s,B11} = \min \left\{ \begin{array}{l} w_x = (x_1 - x_2) : v(x_2) = v(x_1) = 0,1 \cdot v_{0,max,IFE} \\ \max \left\{ \begin{array}{l} 7d + b + t \\ 10d + 1,3y_{cs} \end{array} \right. \end{array} \right. \tag{Eq. 25}$$

$$w_{s,max} = \max \begin{cases} 7d + b_x + t_p & \text{for } y = 0 \\ 10d + 1,3y_{cs} \end{cases} \tag{Eq. 26}$$

$$w_{s,min} = \min \begin{cases} 7d + b_x + t_p & \text{for } y = y_{max} \\ 10d + 1,3y_{cs} \end{cases}$$

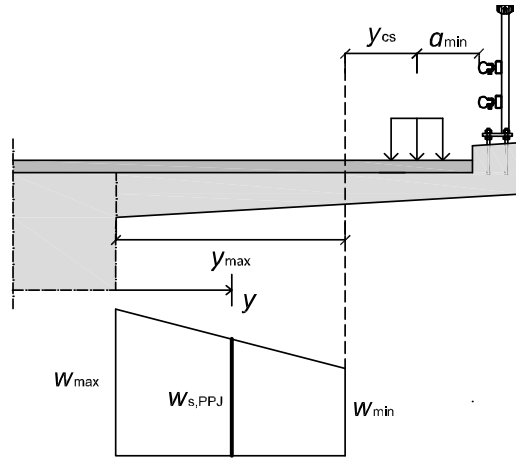

Figure 41: Calculation of the distribution width for shear forces according to Pacoste et. al. (2012)

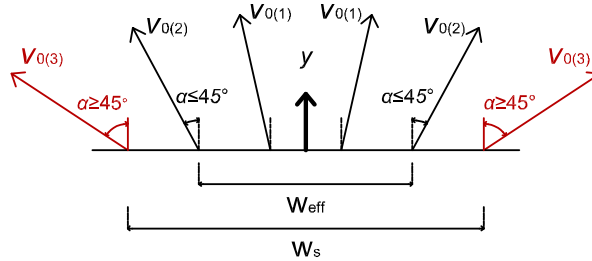

Figure 42: Limiting condition for the distribution width $w_{x,m}$

4.5.3. Concrete shear resisting capacity

The second step in the process is to verify the criteria calculating the concrete nominal shear resisting capacity v_{Rd} . The origin of this contribution of concrete comes from Ritter (1899) who is considered the first person to present the concept of diagonal tension in the web of a beam (Taub & Neville, 1960). An analogy with a truss structure where the stirrups

contributed in tension was formulated. Mörsch (1909) stated that such diagonal tension brought about the failure and stated that v_{Rd} depended only on the concrete compressive capacity. Talbot (1909) added that the flexural reinforcement, the height and the span of the beam also contributed. A formula to calculate the shear resisting capacity of concrete was developed by Clark (1951) accounting for these factors. Taylor (1974) summarized the contributions of different mechanisms to shear resistance capacity of concrete and estimated its magnitude:

- Compression stresses in the non-cracked concrete (20-40%).
- Arch action, depending on the distance to the support and the longitudinal reinforcement in the surrounding area.
- Aggregate interlock or crack friction (35-50%).
- Dowel action from the longitudinal reinforcement (15-25%).

Another *mechanism* recently discussed is the consideration of the influence of a variable depth in a RC slab. A positive effect as means of increased shear resistance can occur because of the contribution of the top compressed concrete chord (V_{ccd}) and the bottom tensile reinforcement chord (V_{td}). A review on the available codes and experimental tests carried out to investigate this effect are discussed below.

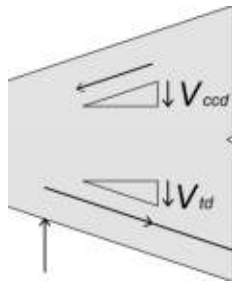

Figure 43: Contribution to the shear resisting capacity of the top compressed concrete chord and the bottom tensile reinforcement chord for a beam close to the support

Formulation for non-prestressed RC members without stirrups

The formulation presented in the Eurocode (CEN, 1998) to calculate v_{Rd} (**Eq. 27**) is based originally on the empirical mathematical expressions presented by (Zsuty, 1971). The critical cross section is considered to be at a distance of half the effective depth ($2d$) from the load applica-

tion. However, in Sweden, Bro11 recommends to use $d/2$ instead (Trafikverket, 2011b). The minimum shear reinforcement may be omitted in members such as slabs where transverse redistribution of loads is possible. The influence of a tapered geometry should be considered for members with stirrups, even though in some countries it is allowed to use for members without (Rombach & Kohl, 2013). Zanuy & Gallego (2015) concluded that it is not consistent to account for such effect if Eurocode is used because of the different background of both equations.

The formulation of ACI318-15 (ACI [American Concrete Institute], 2014) to calculate v_{Rd} (**Eq. 28**) is based on modified compressed field theory. The influence of the size effect ξ is not reflected. The consideration of an inclined compressive chord is expressed as means of a flexure-shear interaction V/M . Such expression is considered to be suitable according to experimental tests (Zanuy & Gallego, 2015).

The formulation presented in the Model Code (CEB-FIP, 2013) is based on a comprehensive mechanical model presented by Bentz, Vecchio, & and Collins (2006). This model also implicitly considers the interaction between bending and shear (**Eq. 29**). The critical cross section is considered to be at a distance of half the effective depth ($d/2$) from the load application. The cross-section close to the support is recommended to be checked.

The nominal shear strength v_{Rd} according to the old Swedish code BBK94 is calculated according to (**Eq. 30**). This formulation uses directly the tensile strength of concrete f_{ct} with no top limitation. The critical cross section is considered to be at a distance of half the effective depth ($d/2$). The positive or negative influence of a tapered height beam or slab may be considered for the calculation of v_{Rd} with a term v_i , represented in **Eq. 31-32**.

Eurocode

$$v_{Rd,CEN} = C_{Rd,c} \cdot \xi \cdot (100 \cdot \rho_l \cdot f_c)^{1/3} \cdot d \text{ [kN/m]}$$

$$\xi = 1 + \sqrt{\frac{200 \text{ [mm]}}{d}}$$

$$v_{Rd,min} = (0,035 \cdot \xi^{3/2} \cdot f_c)^{1/2}$$
(Eq. 27)

ACI 318-15

$$v_{Rd,ACI} = \left(0,16 \cdot \sqrt{f_c} + 17 \cdot \rho_l \cdot \frac{Vd}{M} \right) \cdot d \text{ [kN/m]} \quad (\text{Eq. 28})$$

Model Code (one-way shear)

$$v_{Rd,MC90} = \frac{0,4}{1 + 1500\varepsilon_s} \cdot \frac{1,300}{1000 + s_{xe}} \cdot z \cdot \sqrt{f_c} \text{ [kN/m]} \quad (\text{Eq. 29})$$

BBK94

$$v_{Rd,BBK} = \xi_{BBK} \cdot (1 + 50 \cdot \rho_l) \cdot 0,30 \cdot f_{ct} \cdot d \text{ [kN/m]}$$

$$\xi_{BBK} = \begin{cases} 1,4 & \text{for } d \leq 0,2 \\ 1,6 - d & \text{for } 0,2 < d \leq 0,5 \\ 1,3 - 0,4d & \text{for } 0,5 < d \leq 1 \\ 0,9 & \text{for } d > 1 \end{cases} \quad (\text{Eq. 30})$$

$$v_{Rd,eff} = v_{Rd} + v_i \text{ [kN/m]} \quad (\text{Eq. 31})$$

$$v_i = \frac{m_d}{d} \tan \alpha = \frac{m_d (t_2 - t_1)}{d \cdot a} \text{ [kN/m]} \quad (\text{Eq. 32})$$

Where:

- $C_{Rd,c}$ is a factor that depends on experimental tests
- d is the effective depth
- ξ is a factor accounting for the size effect
- ρ_l is the flexural reinforcement ratio, $\rho_l \leq 0,02$
- f_c is the compressive strength of concrete measured on cylinders.
- ε is the strain at the critical cross-section in the fiber located at $0,6d$ from the extreme compression fiber
- ε_s is the strain at the tensile reinforcement
- s_{xe} accounts for the influence of the aggregate size
- z is the effective shear depth
- m_d is the design bending moment

4.6. Experimental tests on RC cantilever slabs

A bridge designer may wonder which failure type will eventually occur in reality. A ductile flexural failure is obviously preferred compared to a brittle shear failure. This fact can be related to the use of transversal reinforcement, which has been a recent discussion topic among engineers in Sweden. Contractors aim not to use stirrups in order to ease the construc-

tion and save expenses. This section describes experimental tests to provide more knowledge about the strength of RC cantilever slabs depending on factors such as the presence of an edge beam, the amount of flexural reinforcement, the use of stirrups, the load position and the geometrical arrangement.

Miller, Aktan, & Shahrooz (1994) performed a destructive test on a 38 year old decommissioned concrete slab bridge under two concentrated loads. The bridge failed in shear not reaching the theoretical flexural failure load. Yield occurred just before failure. Ibell & Morley (1999) conducted series of full scale tests on a concrete beam-and-slab bridge deck with no stirrups under concentrated loads. The specimens failed in shear and no or limited yielding was documented.

Lu (2003) carried out a series of 9 tests on reduced scale RC cantilever without stirrups. Different reinforcement ratios and load configurations, and the effect of an edge beam were studied. For low reinforcement ratios a ductile failure was observed terminated by a secondary shear failure. High reinforcement ratios led to a sudden brittle shear failure, but increased the strength of the slab. For the case of an edge beam an increase of the load capacity and slightly more ductile behavior was documented (**Figure 44**). The shear crack did not go through the edge beam but developed within the slab region between the cantilever root and the edge beam. Recommended guidelines for design of RC bridge cantilevers were presented, including a proposal for punching control perimeters for cases with and without edge beam based on the topology of the critical sections. A reasonable agreement was found with the experimental tests.

Vaz Rodrigues R. (2007) studied the shear strength of RC bridge deck slabs without shear reinforcement. Six large-scale tests on two cantilevers with different load configurations and flexural reinforcement ratios were carried out. A brittle shear failure was observed. The theoretical flexural failure load was never reached. The failure load increased with the number of applied loads. For the tests performed with the same number of loads, the failure load decreased with the reinforcement ratio. Significant yielding occurred in top and bottom reinforcement for test DR1a (four concentrated loads). For the rest of the tests no or very limited yielding was reported. The critical shear cracks did not seem to form from

the existing flexural cracks. A non-linear model that could predict displacements and rotations was presented. The experimental results resulted in good agreement with the shear criteria proposed by Muttoni (2003).

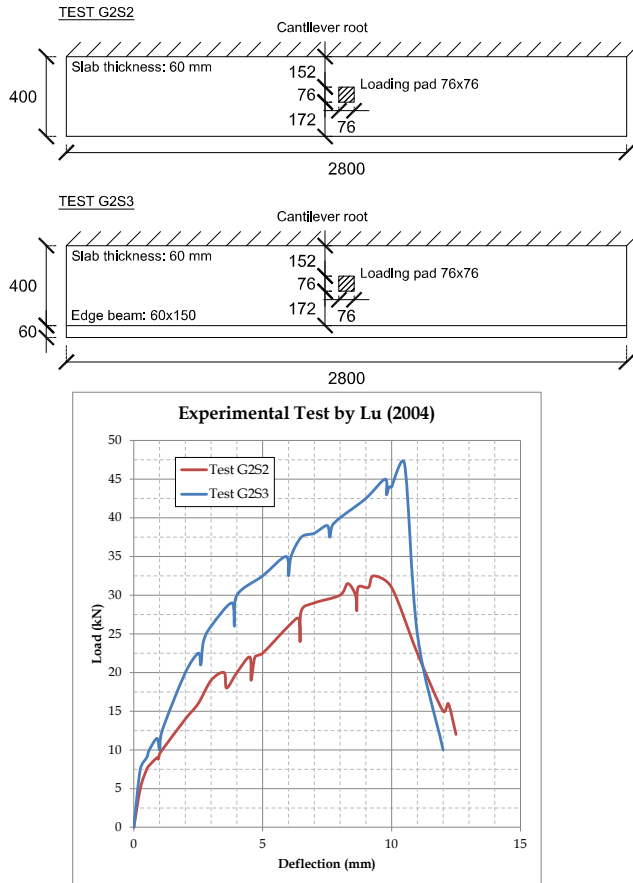

Figure 44: Test configurations and load-deflection curves for a slab without an edge beam (Test G2S2) and with an edge beam (Test G2S3). Adapted from Lu (2003)

Rombach & Latte (2008) conducted 12 large-scale tests on four specimens. The influences of the stirrups and of an inclined tapered thickness were studied. A spontaneous brittle shear failure was observed for the cantilever slabs without stirrups. The bending reinforcement did not yield. The load capacity measured was higher than the one calculated

from design. The specimens with stirrups had a ductile bending failure, with a considerable yielding plateau. The influence of the tapered thickness almost was not perceptible, which led to the performance of new series of tests but in this case with single supported beams (Rombach, Kohl, & Nghiep, 2011). The contribution of the concrete compressed chord was studied as means of inclining the top part with angles varying from 0-10 degrees. A brittle spontaneous shear failure was documented among great part of the slabs, except the ones with higher angle of inclination which had a bending failure. In terms of the total load resisting capacity, the consideration of a positive influence of the inclined haunch could lead to unsafe results for designing concrete members with varying depth without shear reinforcement. Zanuy & Gallego (2015) carried out a parametric analysis based on the tests and suggested that there is an optimal value of the haunch angle that provides the highest shear strength.

4.7. Non-linear FE-analysis

In order to account for the influence of the edge beam on the structural behavior of the concrete bridge deck slab a non-linear 3D FE-model with continuum elements should be created. Shell elements, in contrast, are not suitable to represent shear failure for this case. For its validation experimental tests on concrete deck slabs should be resembled. For Sweden it is a good alternative to use the ones carried out by Vaz Rodrigues R. , 2007. The reason is that the scale of the tests (3/4 of Swiss bridges) almost corresponds with the real Swedish bridge dimensions. The goal in this thesis was not to find a model varying parameters for each experimental test, but to use the same validated FE-model for all the tests studied. Once this goal is achieved, the same FE-model can be used for other purposes, such as the addition of an edge beam, the influence of different concrete thicknesses, reinforcement ratios, etc.

4.7.1. Material definition

Depending on the FE-program used different material models will exist for each material. In this work, the commercial software for numerical simulations ABAQUS has been used. In ABAQUS a material model considered adequate to represent the concrete behavior is "Concrete Damaged Plasticity", as it can both describe compressive and tensile failure. The input data from the experimental test corresponding to each material

should be used. If such information is not available, different methods to define the behavior of the material in the literature exist. A good description and comparison between stress-strain curves can be found in Kmiecik & Kaminski (2011). General background about numerical models in concrete and its use to predict shear type crack initiation is presented in Malm (2009). For the steel, a material model that can be used is “Plastic”, which allows for a plastic isotropic hardening after yielding.

4.7.2. Analysis procedure

In this study, the ultimate load of the RC deck slab is characterized by brittle failure which causes a sudden change in the structural behavior and results in singularities of the tangent stiffness matrix. Therefore, convergence issues may arise if a static analysis is used with Newton-Raphson or arc-length approaches.

Instead, a dynamic analysis can be performed. An explicit solver was used because it can be considered efficient for the kind of problem studied which involves large deformations. Since this procedure is intended for dynamic problems, a quasi-static approach where the loads are applied in a smooth manner was used. This method prevented inertial forces affecting the results considerably. The acceleration varies only a small amount each increment. These inertial effects can be also attenuated by introducing material damping or adjusting the mass properties. The total energy of the model should be compared to internal kinetic energy to ensure that inertial effects do not influence the outcome.

In reality, the consecution of the experimental tests is carried out in a quasi-static manner, as the load is applied by using a controlled velocity in order to reach failure. Nevertheless, a real time-scale representation of the test is not practical as too much computational need is required. The problem should be accelerated in some manner having as a goal the modeling of the event in the shortest time possible where the inertial forces remain negligible. The influence of the time-step needs to be studied in order to reach a consistent solution.

4.8. The influence of the edge beam

Paper II addresses the influence of an edge beam in the structural behavior of a RC bridge overhang. An additional study using a linear-elastic FE-analysis is presented in this section. The influence of the presence and absence of an edge beam applying the failure load Q_{exp} in the experimental tests by Vaz Rodrigues R. (2007) is investigated. The size of the edge beam considered was 400 x 400 mm². The distribution widths for shear $w_{s,PPJ}$ and bending moment $w_{m,PPJ}$ used follow the guidelines by Pacoste et. al. (2012).

Shear force

Figure 46 shows the distribution of the total shear force per unit width v_0 along the corresponding critical cross section for tests DR1a, DR1b and DR1c, illustrated in **Figure 45**. The maximum values of the shear force per unit width from the FE-model ($v_{1FE,max}$) and the distributed shear force ($v_{1FE,dist}$) are presented in **Table 1**.

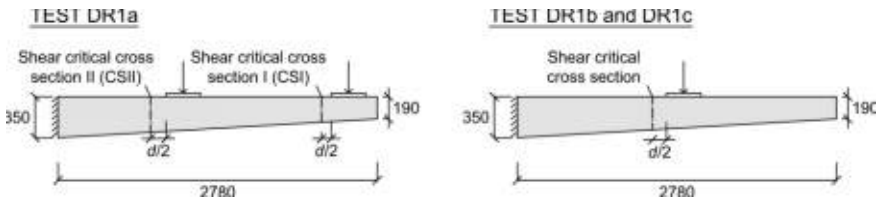

Figure 45: Shear critical cross sections for tests DR1a, DR1b and DR1c

Table 1: Maximum shear force per unit width ($v_{1FE,max}$) and distributed shear force per unit width ($v_{1FE,dist}$) using the distribution widths ($w_{s,PPJ}$) for the failure load in the experimental tests (Q_{exp})

Test	Q_{exp} [kN]	$w_{s,PPJ}$ [mm]		$v_{1FE,max}$ [kN/m]			$v_{1FE,dist}$ [kN/m]			$\frac{v_{1FE,max}}{v_{1FE,dist}}$	
		nEB	EB	nEB	EB	nEB/EB	nEB	EB	nEB/EB	nEB	EB
DR1a CS-I	1397	1709	2937	362	313	0,86	274	189	0,69	1,32	1,65
DR1a CS-II	1397	4142	4142	558	531	0,99	324	312	0,96	1,72	1,71
DR1b	1025	3370	3370	551	547	0,99	314	314	1,00	1,75	1,74
DR1c	910	2890	2890	768	762	0,99	325	324	1,00	2,36	2,33

nEB: without edge beam; EB: with edge beam

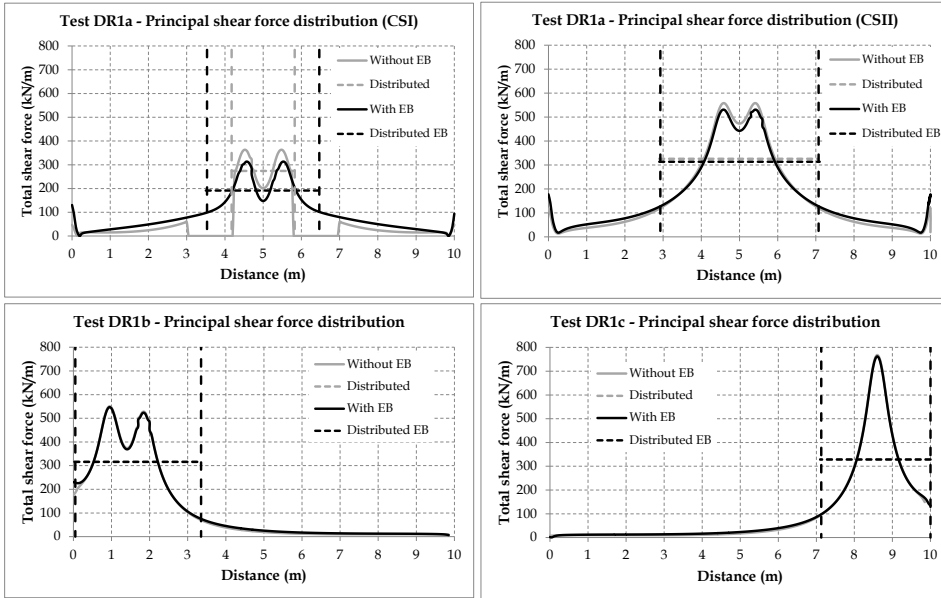

Figure 46: Total shear force distribution and corresponding distribution widths $w_{s,PPJ}$ along the critical cross sections for tests DR1a, DR1b and DR1c for the case of Q_{exp}

Even though the presence of an edge beam is not clearly distinguished by the formulae to calculate $w_{s,PPJ}$, an interesting fact to highlight is the change of the shear flow direction because of such member. The stream lines become more perpendicular to the support which affects the limitation for the calculation of $w_{s,PPJ}$ visualized in **Figure 42**. This limitation affects the case test DR1a in the critical cross section I. The edge beam influences the shear distribution concerning the loads placed closest to the free edge whereas it is almost negligible for the loads closest to the root of the overhang. These results are in the line of the ones presented previously by Vaz Rodrigues R. (2007).

Bending moment

Figure 47 shows the distribution of m_y for Q_{exp} . The cases with and without edge beam are presented for tests DR1a, DR1b and DR1c. For the calculation of $w_{m,PPJ}$ the ratio x_u/d calculated was 0,13. Thus, the second formula in **(Eq. 17)** has been used. A comparison between the maximum

transversal bending moment from the FE-model ($m_{y,max}$) and the distributed one ($m_{y,distr}$) is presented in **Table 2**.

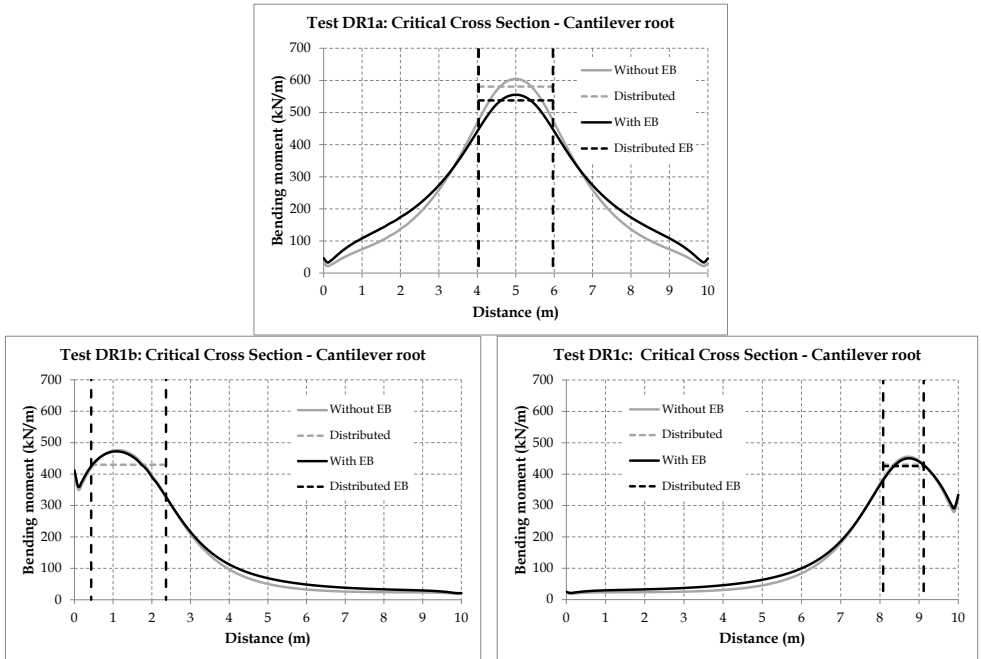

Figure 47: Bending moment distribution m_y and distribution widths $w_{m,PPJ}$ along the critical cross sections for tests DR1a, DR1b and DR1c for the case of Q_{exp}

Table 2: Maximum transversal bending moment distribution ($m_{y,max}$) and distributed transversal bending moment ($m_{y,distr}$) following the distribution widths ($w_{s,PPJ}$) for the total load failure in the experimental tests Q_{exp}

Test	Q_{exp} [kN]	$w_{m,PPJ}$ [mm]		$m_{y,max}$ [kN/m]			$m_{y,distr}$ [kN/m]			$\frac{m_{y,max}}{m_{y,distr}}$	
		nEB	EB	nEB	EB	nEB / EB	nEB	EB	nEB / EB	nEB	EB
DR1a	1397	1934	1934	604	555	1,09	581	538	1,08	1,04	1,03
DR1b	1025	1934	1934	476	472	1,01	456	450	1,01	1,11	1,11
DR1c	910	1034	1034	430	427	1,01	430	426	1,01	1,06	1,06

EB: without edge beam; EB: with edge beam

A smooth reduction of m_y at the cantilever's root exists for the case of four concentrated loads (test DR1a), which is in agreement with the results presented by Vaz Rodrigues R. (2007). The FE-model, in contrast with hand-calculation methods, considers the presence of the edge beam. With respect to the case of one or two concentrated loads near the canti-

lever root and the longitudinal free edge (tests DR1b and c) such effect can be considered negligible.

4.8.1. Development of design curves for moment

Homberg & Ropers diagrams are currently used in Sweden as a hand-calculation method. This may lead to conservative results. Therefore, it is suggested that similar graphs as the ones initially developed by Bakht are built for the Swedish case using adequate edge beam ratios to calculate $m_y(x, y)$. **Figure 50** shows the coefficients A' that should be used for different relative load positions c/a . The ratios l_{eb}/l_s used are 0,38 and 0,57, which correspond to edge beam sizes of 400x400 mm² and 600x400 mm², and a slab of the dimensions of a bridge in Stockholm. Because of the elastic-linear nature of this analysis, for multiple load cases P_i the curves obtained could be added together in order to obtain the transversal moment distribution. **Figure 49** shows an example of the calculation of the distribution of m_y at the root of the cantilever for four concentrated loads corresponding to load model 1 of the Eurocode. A similar procedure could be done to derive the maximum and minimum longitudinal bending moment in the edge beam ($M_{x,max}$ and $M_{x,min}$), as presented by Bakht (1981). The formulae presented in **Eq. 33-34** could be used for the crack control check in the edge beam.

$$\frac{M_{x,max}}{Pa} = F_{I1} \quad (\text{Eq. 33})$$

$$\frac{M_{x,min}}{Pa} = F_{I2} \quad (\text{Eq. 34})$$

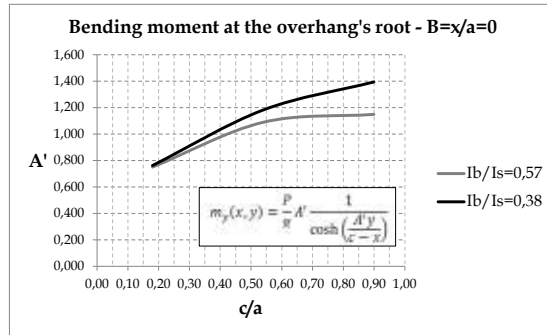

Figure 48: Proposed A' coefficients to be used for the case of a typical Swedish bridge for the calculation of a) $m_y(x, y)$ at the overhang's root

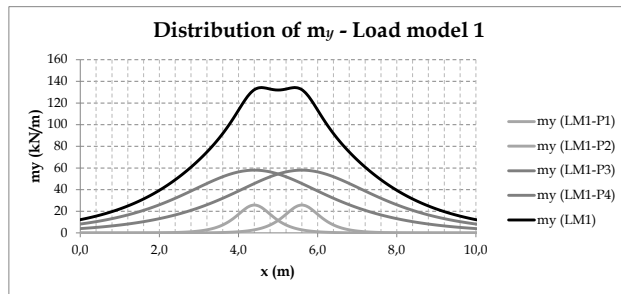

Figure 49: Calculation of m_y for four concentrated loads P_i corresponding to load model 1 of the Eurocode

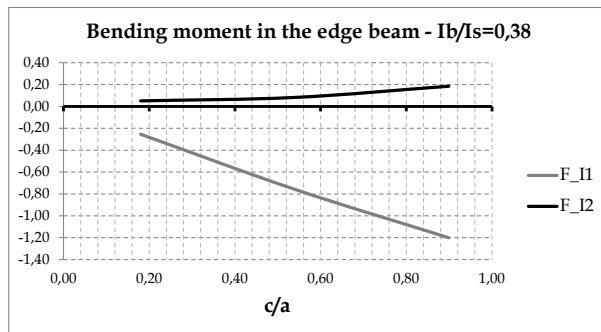

Figure 50: Proposed A' coefficients to be used for the case of a typical Swedish bridge for the calculation of $M_{x,max}(x, y)$ and $M_{x,min}(x, y)$ in the edge beam

4.9. A solution without an edge beam

A solution without an edge beam should ensure that the requirements explained in **Section 2.2** are fulfilled. A steel plate can be mounted from the side to function as support of the overlay and contribute to the drainage system. The railing can be top- or side-mounted. The former is traditionally used in Sweden. Trafikverket, which owns great part of Swedish bridges, would allow the use of the latter if it is CE-labelled, which is currently provided by certain railing manufactories in Sweden. A wide variety of side-attached railings can be found in North America.

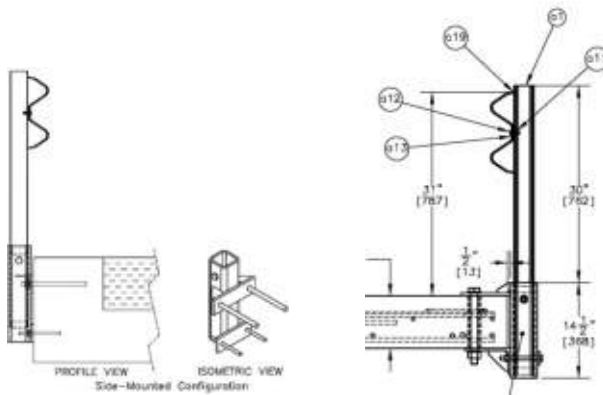

Figure 51: Examples of side-mounted railing in USA (Midwest Roadside Safety Facility, 2010)

From a structural point of view, for bridge decks with an overhang the increased load-capacity that the edge beam provides should be “replaced” in some manner if this member is removed to keep the bridge’s robustness. This fact will need to be addressed by the design engineer. An alternative could be to increase the thickness of the concrete in the area close to the free edge. Another option could be to include transversal reinforcement. However, this would imply undesired additional costs and the contractors would prefer to avoid this choice.

As explained in **Section 2.5.2**, Trafikverket, after the edge beam group project, has decided to implement a new steel edge beam solution proposed by the consulting firm Ramböll in a frame bridge. In reality, the steel edge beam is not contributing to the distribution of concentrated

loads. This was not relevant a frame bridge was considered. If this solution is to be implemented in a bridge with an overhang the considerations explained above should be accounted for.

Apart from the solution presented in **Section 2.5.1**, another proposal without an edge beam has been proposed by the Swedish construction company NCC. The design consists of a side-mounted railing with a continuous steel plate along the bridge deck. A prototype of this solution for a frame is visualized in **Figure 52**.



Figure 52: Prototype of a solution without an edge beam for a bridge deck with an overhang (left part) and a frame bridge (right part)

4.10. Summary

- The edge beam design can be affected by non-structural related factors associated with other components in the BEBS. The Swedish bridge code Bro 11 presents requirements and recommendations to be followed (Trafikverket, 2011a-b).
- Experimental tests in the literature show that RC overhang slabs without transversal reinforcement will most probably fail in shear. If stirrups are present a ductile bending failure would be expected. The consideration of the inclined chords for an increased shear resistance capacity still remains unclear.
- A two-step procedure with a cross-sectional analysis can be performed to design RC bridge deck overhangs using simplified design methods or through a linear-elastic FE-analysis, as described in this chapter. Distribution widths for bending moments and shear forces should be used. A non-linear analysis can be con-

templated as a one-step procedure where the load capacity of the RC slab is directly obtained.

- The presence of the edge beam should be accounted for in the design of RC overhang slabs. The flow of shear forces is modified and the load capacity is increased. Distribution widths according to Pacoste et. al. allow for the consideration of such effect.
- A solution without an edge beam could result better for the society in terms of cost. Principal issues concerning functional aspects have been addressed. From a structural point of view, the removal of the edge beam in a bridge with an overhang should be investigated in the design phase.

5. Conclusions

5.1. General conclusions

This thesis is meant to represent a stepping stone for further research in the field of bridge edge beam systems. New concepts related to BEBS proposals that can become better for the society in terms of cost and that can fulfill the functional requirements - including structural – have been evaluated. For that purpose new concepts are investigated as means of LCCA and structural analysis. In this regard, the work presented is associated to a project started by Trafikverket called “More robust bridge decks” (Sundquist, 2011). This project aims to develop efficient bridge deck solutions concerning lower *LCC* and enhanced constructability. As a result, more robust bridge decks as means of higher load capacity and less life-cycle measures needed are sought. The following general conclusions from the research carried out are presented:

5.1.1. LCCA (*Paper I – Chapter 3*)

- LCCA is a tool that can be used for the development of new BEBS solutions that can be better for the society in terms of cost in order to evaluate and compare them. The group proposals from the edge beam group have been evaluated. For long bridges the concrete integrated edge beam (Type I) may be a good solution whereas for short bridges the prefabricated edge beam (Type IV) may be a suitable solution. Type II and III can qualify for further detailed studies and are proposed for thorough study and subsequent implementation in a real bridge project. An adequate definition of a LCS for the bridge case considered is paramount.
- A low value of the discount rate encourages the investment in better quality solutions (high INV costs) that do not require im-

portant maintenance (low LCM costs) during the life span. This is the case for stainless steel, which can be used to extend the design life span of the BEBS. The total LCC is shown to be lower in comparison to a design solution with normal steel because of the LCM costs and, especially, the user costs. Proposals of the reinforcement layout have been presented.

5.1.2. Structural analysis (*Paper II – Chapter 4*)

- The presence of an edge beam increases the load capacity of RC overhang slabs for loads placed near the free edge. This ‘stiffening effect’ is related with the edge beam’s load-carrying function. An efficient distribution of the shear resisting capacity of the RC overhang slab was observed. The influence of the edge beam for loads close to the overhang root is almost insignificant.
- Consequently, if compared with existing road bridges, the removal of the edge beam would imply loss of robustness to that of an overhang with an edge beam. Thus, the depth of the cross section closest to the transversal free edge of the overhang might need to be increased to maintain the same load capacity.
- Quite conservative estimates are obtained for simple hand calculations, even more if a punching problem is contemplated. The code BBK94 may over predict the total load resisting capacity of the bridge overhang. This could motivate the lack of desired sufficient robustness of Swedish bridges. This fact is accentuated if a positive influence of a variable depth is considered. The influence of the edge beam should be accounted for in the existing design regulations for loads applied near the free edge.
- The choice of the maximum shear force and bending moment obtained from the FE-models as the design values is very conservative. The results obtained using the distribution widths proposed by Pacoste et. al. (2012) is considered very adequate, even for the cases with an edge beam.
- Non-linear FE-models with solid elements can predict in an acceptable way the shear failure of RC slabs of bridge overhangs

without stirrups. The total load resisting capacity and the displacement can be obtained. A quasi-static analysis procedure using an explicit solver can be used to prevent convergence issues.

5.2. Design and LCCA

This thesis aims to contribute to bridge the gap between design and LCCA in the field of bridge edge beams. The main problems are related to life-cycle measure costs and their associated user costs. A good design should account for these issues. In other words, the bridge designer should also behave as a bridge manager.

The deterioration of the BEBS is brought about by the mechanisms explained previously in this thesis. The design should be performed in order to face them along the bridge's life span. The edge beam should also be designed accordingly so that an adequate crack distribution is obtained to prevent deterioration and ensure longer life span. If a solution with no actual edge beam is considered, the issues described above concerning functionality and structural behavior should be addressed.

The designer could think about a solution that can last longer so that there is almost no need to apply LCMs. An opposite alternative could be to design a solution that can actually deteriorate but that can be repaired and replaced in an easier and faster manner. It is important to notice that usually user costs are one of the major contributions to the total LCC.

The designer may wonder which of both approaches should be taken. In his double role the definition of an adequate LCS for the bridge case at hand during the preliminary design is paramount. Concurrent maintenance schemes that group LCMs into LCPs allow for the reduction of user costs. A governing "Master" LCM can be chosen to decide on the execution time of a LCP.

Once a LCS has been defined a LCCA can be performed. One of the parameters affecting the approach that could be taken is the discount rate used. A design with low INV costs which are associated to high LCM costs which would be the case of a high discount rate, and vice versa.

5.3. Further research

The following research proposals are suggested:

- Development of a solution without an edge beam addressing more in detailed the aforementioned issues. From the previous proposals, different approaches of how to increase the load capacity lost because of the removal of the edge beam could be investigated. The use of stirrups or the increase of the slab thickness could be decided upon the consecution of a LCCA. An interesting aspect would be the modelling of a vehicle crash. The performance of the connections of the railing to the concrete bridge deck could be inspected.
- Study of the structural design of edge beams. Investigation of critical parts of the bridge such as the transverse free edges or the supports in continuous beam bridges. Calculation of the design bending moment in the edge beam and evaluation of the crack control. Areas over supports are known as a problem, since high reinforcement ratios are required to fulfill the requirements. This implies at the same time that additional load-carrying capacity is attributed to the edge beam. This would enforce the argument of considering the edge beam for the design of the RC deck slab.
- The influence of different thicknesses and inclination angles in the bridge overhang slab, considering dimensions from Swedish bridges. The contribution of a tapered geometry to the shear resisting capacity of the member can be investigated. The location of the critical cross section for shear for multiple concentrated loads is of interest.
- The influence of the flexural reinforcement ratio and the inclusion of transversal reinforcement. An evaluation of the load resisting capacity and the failure mode can be carried out. Besides, the influence of the material models used could be explored, especially different definitions of the compressive and tensile concrete strength.

- Investigation of different failure modes depending on the geometry of the bridge overhang and the size of the edge beam. The limitation between flexural and shear failure through a parametric study can be performed.
- Development of design methods that account for the presence of an edge beam. Proposals of increased nominal concrete shear capacity and the shear distribution widths to be used for simplified calculation methods and FE-analyses.
- Carry out a LCCA for the design proposals that were decided to be studied in detail and implemented in real bridge projects. In this regard, a follow-up of the construction of the steel edge beam in the project of the bridge in Mellösa for the collection of input data to be used could be performed. The definition of an adequate LCS for this case should be investigated.
- Investigation of the life span of the BEBS. The practice of concurrent maintenance can be studied. The condition class of the elements of the BEBS at the moment of execution of the LCM should be documented. The decision making procedure of the bridge manager upon certain circumstances could be reflected.
- Modelling additional experimental tests of RC cantilever slabs with and without an edge beam available in the literature. Give a broader validity to the non-linear FE-model used. If possible, carry out new experimental or field tests on RC bridge deck slabs with and without edge beam, and different overhang spans. A better understanding of the structural behavior in the ultimate limit state should be provided.

References

- ACI [American Concrete Institute]. (2014). *318-14: Building Code Requirements for Structural Concrete and Commentary*. Farmington Hills, Michigan: ACI.
- Adey, B., & Hajdin, R. (2005). Potential use of inventory theory to bundle interventions in bridge management systems. *Transportation Research Board, Vol.1933(1)*, 44-49. doi: 10.3141/1933-06
- Ansnaes, V., & Elgazzar, H. (2012). *Concrete Cracks in Composite Bridges*. Stockholm: KTH Royal Institute of Technology. Retrieved from <http://kth.diva-portal.org/smash/get/diva2:545298/FULLTEXT01>
- Bakht, B. (1981). Simplified Analysis of Edge Stiffened Cantilever Slabs. *Journal of the Structural Division*, 535-550.
- Bakht, B., & Holland, D. (1976). A manual method for the elastic analysis of wide cantilever slabs of linearly varying thickness. *Canadian Journal of Civil Engineering, Vol. 3 (4)*, pp. 523-530.
- Bentz, E., Vecchio, F., & and Collins, M. (2006). Simplified modified compression field theory for calculating shear strength of reinforced concrete elemens. *ACI Structural Journal, Vol. 103 No. 4*, 614-624.
- Boverket. (1994). *Betongkonstruktioner [Concrete design]*. Boverket.
- Canadian Standards Association. (2015). *CAN/CSA-S6 Canadian Highway Bridge Design*. Missisauga, Ontario: Canadian Standards Association.
- CEB-FIP. (2013). *fib Model Code for Concrete Structures 2010*. Lausanne, Switzerland.
- CEN [European Committee for Standardization]. (1998). *EN 1317-2:1998 Road restraint systems - Part 2: Performance classes, impact test acceptance criteria and test methods for safety barriers*. Brussels: CEN.
- Clark, A. (1951). Diagonal Tension in reinforced concrete beams. *ACI Journal 48 (2)*, 145-156.
- Dilger, W. H., Tadros, G., & Chebib, J. (1990). Bending moments in cantilever slabs. *Development in Short and Medium Span Bridges '90, Vol. 1*, pp. 265-276.

- Duran, E. (2014). *Design of edge beams*. Stockholm: KTH Royal Institute of Technology. Retrieved from <http://www.diva-portal.org/smash/get/diva2:732710/FULLTEXT01.pdf>
- Ehregren, E. (2000). *Kantbalkar och räckesinfästningar - nya tekniska lösningar? [Edge beam and railing coupling - New technical solutions?]*. Master Thesis, Uppsala University, Uppsala.
- European Committee for Standardization [CEN]. (2005). *Eurocode 2: Design of concrete structures - Part 1-1: General rules and rules for buildings. EN 1992-1-1*.
- Fasheyi, A. (2013). *Optimal Edge Beam System - International study*. Stockholm: KTH Royal Institute of Technology. TRITA-BKN Tekniska rapport 2013:04, ISSN KTH/BKN/R-04-SE Stockholm, 2013.
- Fédération International du Béton (fib). (2010). *Model code for concrete structures*. Berlin: Ernst & Sohn.
- Frangopol, D. M. (2010). Life-cycle performance, management, and optimisation of structural systems under uncertainty: accomplishments and challenges. *Structure and Infrastructure Engineering: Maintenance, Management, Life-cycle Design and Performance*, 7:6, 389-413. doi: 10.1080/15732471003594427
- Gustavsson, N. (2013, January 15). *100 fordon i masskrock - en man död*. Retrieved October 12, 2015, from Helsingborgs Dagblad: <http://www.hd.se/nyheter/skane/2013/01/15/100-fordon-i-masskrock---en-man-dod/>
- Homberg, H., & Ropers, W. (1965). *Farhrbahnplatten mit veränderlicher Dicke; Erster Band*. Springer-Verlag.
- Huang, Y.-H., & Huang, H.-Y. (2012). A model for concurrent maintenance of bridge elements. *Automation In Construction*, Vol.21, pp.74-80. doi: 10.1016/j.autcon.2011.05.014
- Ibell, T., & Morley, C. M. (1999). Strength and Behavior in Shear of Concrete Beam-and-Slab Bridges. *ACI Structural Journal*, Vol. 96 No. 3, 386-392.
- ISO15686-5. (2008). *Building and constructed assets-service-life planning. Part 5: Life-cycle costing*. Swedish Standard Institute.
- Jaeger, L.-G., & Bakht, B. (1990). Rationalization of simplified methods of analyzing cantilever slabs. *Canadian Journal of Civil Engineering*, Vol. 17(5), pp. 865-867.

- Jaramillo, T. (1950, March). Deflections and Moments due to a Concentrated Load on a Cantilever Plate of Infinite Length. *Journal of Applied Mechanics*, Vol. 72 No. 1, p. A-67 to A-72.
- Jiménez Montoya, P., García Meseguer, Á., & Morán Cabré, F. (2001). *Hormigón Armado*. Gustavo Gili.
- Karim, H. (2011). *Road Design for Future Maintenance - Life-cycle Cost Analyses for Road Barriers*. Doctoral Thesis, KTH Royal Institute of Technology, Stockholm.
- Kelindeman, M. (2014). *Edge Beams. Evaluation of Investment Costs for its application to LCC Analysis*. Master Thesis, KTH Royal Institute of Technology, Stockholm.
- Klowak, C., Mufti, A., & Bakht, B. (2010). Investigating arching-action in bridge deck cantilever slab overhangs subjected to a static and fatigue concentrated load. *Proceedings, Annual Conference - Canadian Society for Civil Engineering*, Vol.2, pp. pp.1028-1037.
- Kmiecik, P., & Kaminski, M. (2011). *Modelling of reinforced concrete structures and composite structures with concrete strength degradation taken into consideration*. Wrocław University of Technology.
- Leprince, & Tomas. (2013, January 17). *Dagens Nyheter*. Retrieved October 12, 2015, from Tranarpsbron öppen för trafik igen: <http://www.dn.se/nyheter/sverige/tranarpsbron-oppen-for-trafik-igen/>
- Lim, S. (2013). *Redistribution of force concentrations in reinforced concrete cantilever slab using 3D non-linear FE analyses*. Master Thesis, Chalmers University of Technology, Göteborg.
- Lu, H.-Y. (2003). *Behaviour of reinforced concrete cantilevers under concentrated loads*. PhD Thesis, University of Cambridge, Girton College.
- Lüthi, T., & Zwicky, D. (2007). The Balsberg Viaduct of the new light rail network to Zurich-Airport. *Improving Infrastructure Worldwide - Bringing People Close*. Vol. 93, pp. 25-32. Weimar: International Association for Bridge and Structural Engineering Symposium.
- Maglica, A. (2012). Ölandsbrons kantbalkar har fått katodiskt skydd [The edge beams in the Öland bridge have cathodic protection]. *Nr 1*, pp. 11-12. Retrieved from http://www.bygging.se/husbyggaren/artiklar/2012_1_02.pdf

- Malm, R. (2009). *Predicting shear type crack initiation and growth in concrete with non-linear finite element method*. KTH Royal Institute of Technology.
- Mattson, H.-Å., Sundquist, H., & Silfwerbrand, J. (2007). The Real Service Life and Repair Costs for Bridge Edge Beams. *Restoration of buildings and monuments, Vol. 13, No. 4*, pp. 215-228. doi: 10.1515/rbm-2007-6140
- Midwest Roadside Safety Facility. (2010). *Development of a low-cost, energy-absorbing bridge rail*. Lincoln, Nebraska: Midwest Roadside Safety Facility.
- Miller, R., Aktan, A., & Shahrooz, B. (1994, July). Destructive Testing of Decommissioned Concrete Slab Bridge. *ASCE Journal of Structural Engineering, Vol. 120 No 7*, 2176-2198.
- Mirzaei, Z., & Adey, B. (2014). An Inventory Theory Model to Determine the Optimal Work Program for Bridges. *Canadian Society for Civil Engineering [CSCE] - Annual Conference. G5 - Sustainable Infrastructure*, pp. 1-10. Halifax, Nova Scotia: CSCE.
- Mufti, A. A., Bakht, B., & Jaeger, L. G. (1993). Moments in deck slabs due to cantilever loads. *Journal of structural engineering New York, N.Y., 119(6)*, 1761-1777.
- Muttoni, A. (2003). Schubfestigkeit und Durchstanzen von Platten ohne Querkarftbewehrung. *Beton- und Stahlbetonbau, Vol. 8 No. 2*, 74-87.
- Myndigheten för samhällsskydd och beredskap [Swedish Civil Contingencies Agency]. (2013). *Trafikolycka Tranarpsbron : Faktablad*. Karlstad: Myndigheten för samhällsskydd och beredskap.
- Mörsch, E. (1909). *Concrete-Steel construction*. New York: Mc Graw Hill
- Nishibayashi, M., Kanjo, N., & Katayama, D. (2006). Toward more practical BMS: Its application on actual budget and maintenance planning of a large urban expressway network in Japan. In P. Cruz, D. Frangopol, & L.-C. Neves (Ed.), *3rd International Conference on Bridge Maintenance, Safety and Management* (pp. 915-916). Porto: Bridge Maintenance, Safety, Management, Life-Cycle Performance and Cost.
- Pacoste, C., Plos, M., & Johansson, M. (2012). *Recommendations for finite element analysis for the design of reinforced concrete*

- slabs*. Stockholm: KTH Royal Institute of Technology, ELU and Chalmers Institute of Technology.
- Pettersson, L., & Sundquist, H. (2014). *Optimal Edge Beams: Results of the Research, Development and Demonstration project (Optimala kantbalkssystem: Resultat av genomfört FUD-projekt)*. (Technical Report 2014:151). Stockholm: KTH Royal Institute of Technology. Retrieved from DiVA Portal: <http://kth.diva-portal.org/smash/record.jsf?pid=diva2%3A761605&dsid=5931>
- Plos, M., Shu, J., Zandi, K., & Lundgren, K. (2015). *A multi-level structural assessment proposal for reinforced concrete bridge deck slabs*. Göteborg: Chalmers University of Technology.
- Pucher, A. (1951). *Einflussfelder elastischer Platten*. Wien: Springer Verlag.
- Racutanu, G. (2001). *The Real Service Life of Swedish Road Bridges - A Case Study*. Stockholm: KTH Royal Institute of Technology.
- Ramos, D. (2015). *Steel edge beam*. Stockholm: KTH Royal Institute of Technology.
- Reismann, H., & Cheng, S.-H. (1970). The edge reinforced cantilever plate strip. *IABSE Publications*.
- Ritter, W. (1899). Die bauweise hennebique. In W. Ritter, *Schweizerische Bauzeitung* (Vol. Vol. 33, pp. 59-61).
- Rombach, G., & Kohl, M. (2013, December). Shear Design of RC Bridge Deck Slabs according to Eurocode 2. *Journal of Bridge Engineering*, 1261-1269. doi:10.1061/(ASCE)BE.1943-5592.0000460
- Rombach, G., & Latte, S. (2008). Shear resistance of bridge decks without shear reinforcement. In J. Walraven, & Stoelhorst, D. (Ed.), *Proc., fib Symp.: Tailor Made Concrete Structures* (pp. 519-525). London: Taylor&Francis.
- Rombach, G., & Latte, S. (2009). "Querkrafttragfähigkeit von Fahrbahnplatten ohne Querkraftbewehrung [Shear resistance of deck slabs without shear reinforcement]. *Beton- und Stahlbetonbau, Vol. 10*, 1-15.
- Rombach, G., Kohl, M., & Nghiep, V. (2011). Shear design of concrete members without shear reinforcement - A solved problem? *Proc. 12th East Asia-Pacific Conf. on Structural Engineering and Construction. Vol. 14*, pp. 134-140. Elsevier.

- Safi, M. (2013). *Life-Cycle Costing. Applications and Implementations in Bridge Investment and Management - Doctoral Thesis*. Stockholm: KTH Royal Institute of Technology. Retrieved from <http://www.diva-portal.org/smash/record.jsf?pid=diva2:660312>
- Safi, M., Du, G., Sundquist, H., & Karoumi, R. (2013). Holistic Approach to Sustainable Bridge Procurement Considering LCC, LCA, Lifespan, User-Cost and Aesthetics: Case Study. *Journal of Bridge Engineering - ASCE [American Society of Civil Engineers]*.
- Salokangas, L. (Ed.). (2009). *ETSI Project (Stage 2): Bridge Life Cycle Optimisation*. Espoo: Helsinki University of Technology.
- Samuelsson, K. (2005). *Sprickrisk vid byte av kantbalkar - inverkan av kylning (Risk of crack formation in the edge beam replacement - Influence of cooling)*. Göteborg: Chalmers Technical Institute. Master Thesis 2005:29.
- Sawko, F., & Mills, J. (1971). Design of cantilever slabs for spine beam bridges. *Proceedings of the Cardiff Conference*. Crosby Lockwood and Son Ltd. London.: Crosby Lockwood and Son Ltd.
- Shams Hakimi, P. (2012). *Distribution of Shear Force in Concrete Slabs*. Master Thesis, Chalmers Institute of Technology, Göteborg.
- Silfwerbrand, J. (2008). *Impregnation of Concrete Bridge Elements Exposed to Severe Environment - Is it cost effective?* Brussels, Belgium: Hydrophobe V - the 5th International Conference on Water Repellent Treatment of Building Materials.
- Smith, K. N., & Mikelsteins. (1988). Load distribution in edge stiffened slab and slab-on-girder bridge decks. *I Canadian Journal of Civil Engineering, Vol.15(6)*, pp. 977-983.
- Sundquist, H. (2010). *Elastic Plate Theory for Bridge Superstructures*. Stockholm: KTH Royal Institute of Technology.
- Sundquist, H. (2011). *Robustare brobaneplatta [More robust bridge decks]*. KTH Royal Institute of Technology, Chalmers Institute of Technology and LTH Institute of Technology. Stockholm: Sveriges Byggnadsuniversitet.
- Sundquist, H., & Jutila, A. (Eds.). (2007). *ETSI Project (Stage 1): Bridge Life Cycle Optimisation*. Espoo, Finland.
- Talbot, A. (1909). *Test of Reinforced Concrete Beams: Resistance to Web Stresses (Vol. VI No.12)*. Urbana-Champaign: University of Illinois Engineering Experiment Station.

- Taub, J., & Neville, A. (1960). Resistance to shear of reinforced concrete beams. Part I: Beams without web reinforcement. *ACI Journal*, Vol. 57, 193-220.
- Taylor, H. (1974). The Fundamental Behavior of Reinforced Concrete Beams In Bending and Shear. *ACI Journal*, Vol. SP-42, 43-77.
- Thoft-Christensen, P. (2011). Infrastructures and life-cycle cost-benefit analysis. *Structure and Infrastructure Engineering: Maintenance, Management, Life-Cycle Design and Performance*, 8:5, 507-516. doi: 10.1080/15732479.2010.539070
- Trafikverket [The Swedish Transport Administration]. (2011a). *TRVK Trafikverkets Tekniska Krav Bro 2011:085 [Technical Requirements for Bridges by the Swedish Transport Administration]*. Stockholm: Trafikverket. Retrieved from Trafikverket: http://publikationswebbutik.vv.se/upload/6500/2011_085_trvk_bro_11.pdf
- Trafikverket. (2011b). *TRVK Trafikverkets Tekniska Råd Bro 2011:086 [Technical Recommendations for Bridges by the Swedish Transport Administration]*. Stockholm: Trafikverket. Retrieved from <http://online4.ineko.se/online/download.aspx?id=42967>
- Trafikverket. (2013). *BaTMan (Bridge and Tunnel Management) - Swedish Bridge Management System*. Stockholm: Trafikverket. Retrieved from <https://batman.vv.se/>
- Trafikverket. (2015). *Samhällsekonomiska principer och kalyvärden för transportsektorn: ASEK 5.2 [Society economic principles and calculation value for the transportation sector ASEK 5:1]*. Borlänge: Trafikverket. Retrieved from <http://www.trafikverket.se/Foretag/Planera-och-utreda/Planerings--och-analysmetoder/Samhallsekonomisk-analys-och-trafikanalys/Gallande-forutsattningar-och-indata/>
- Troive, S. (1998). *Structural LCC Design of Concrete Bridges*. (Doctoral Thesis), KTH Royal Institute of Technology, Stockholm.
- Troive, S. (2008). *Utformning av kantbalkar, State-of-the-art [Design of Edge Beams, State-of-the-art]*. Borlänge: Vägverket [Swedish Road Administration].
- Vaz Rodrigues, R. (2007). *Shear Strength of Reinforced Concrete Bridge Deck Slabs*. École Polytechnique Fédérale de Lausanne.

- Vaz Rodrigues, R., Fernández Ruiz, M., & Muttoni, A. (2008). Shear strength of R/C bridge cantilever slabs. *Engineering Structures*, 3024-3033.
- Veganzones Muñoz, J. J. (2014). *KTH-ABE - Department of Civil and Architectural Engineering, Division of Structural Engineering and Bridges*. Retrieved from Kantbalksprojekt [Edge beam project]: <https://www.kth.se/abe/om-skolan/organisation/inst/byv/about/avd/bro/projekt/kantbalksprojekt/kantbalksprojektet-1.517540>
- Veganzones Muñoz, J. J., & Morán Quijano, F. d. (2013). *Comparative Life Cycle Cost for Two Road Bridges*. Stockholm: KTH.
- Veganzones, J. J., Sundquist, H., Pettersson, L., & Karoumi, R. (2015). Life-cycle Cost Analysis as a tool for the development of bridge edge beams. *Structure and Infrastructure Engineering*.
- Zanuy, C., & Gallego, J. M. (2015). Discussion of Shear Design of RC Bridge Deck Slabs according to Eurocode 2 by Guenter Rombach and Matthias Kohl. *ASCE Journal of Bridge Engineering*, Vol. 20(ISSN 1084-0702), 07014013 1-2.
- Zsuty, T. (1971). Shear strength prediction for separate categories of simple beam tests. *ACI Structural Journal* 68 (2), 138-143.